

PRODUCT DATA SHEET

Published: 2026-03-24

LAUDA filling and flow control system

Based on FD50 / FC80MID, 100-240 V; 50/60 Hz

Part Number: L004011

Features

- Flow control system with magnetic inductive measurement principle
- Permitted heat transfer liquids: water/glycol mixtures
- Useable on LAUDA Integral variants IN XT and IN P
- User-interface allows setting and control of the temperature control unit
- Use in pressurized temperature control units up to max. 140 °C
- Use in open or cold-oil overlay systems up to max. 90 °C
- The maximum controllable volume flow depends on the pump output of the temperature control unit and the pressure drop in the application
- Adjustable pressure limit in application circuit
- With certificate of calibration
- Active filling and draining system for temperature control circuits with changing applications
- Setting the parameters via the operating menu of the temperature control unit
- Automatic filling and emptying sequence, status visualized via illuminated keys
- Demand-related manual override of automation possible
- Calibratable pressure sensors
- Pneumatic leak test before filling
- Auxiliary pump for active support of filling via the thermostat
- Monitoring of the liquid temperature before compressed air discharge
- Large tank reservoir with level detection for handling large quantities of liquid
- Mesh filter against aerosols
- Communication to the temperature control unit via LiBus
- Full process integration via connectivity temperature control unit
- Movable on wheels
- Available accessories: Inline - filter (strainer); Sight glass for venting control; Automatic refill incl. pump; Automatic refill via solenoid valve



Reserve technical changes

LAUDA DR. R. WOBSEY GMBH & CO. KG
Laudaplatz 1 • 97922 Lauda-Königshofen • DE

T + 49 (0) 9343 503-0
info@lauda.de • www.lauda.de
WEEE-Reg.-Nr.: DE 66 42 40 57

Kommanditgesellschaft: Sitz Lauda-Königshofen
Registergericht Mannheim • HRA 560069

Persönlich haftende Gesellschafterin:
LAUDA DR. R. WOBSEY Verwaltungs-GmbH
Sitz Lauda-Königshofen
Registergericht Mannheim • HRB 560226

Geschäftsführer:
Dr. Gunther Wobser (Vors.), Dr. Mario Englert,
Dr. Marc Stricker
Beirat: Dr. Gerhard Wobser

PRODUCT DATA SHEET

Published: 2026-03-24

LAUDA filling and flow control system

Based on FD50 / FC80MID, 100-240 V; 50/60 Hz

Part Number: L004011

Technical Features (valid with Kryo 30)

Working temperature range	10 ... 40 °C
Ambient temperature range	5 ... 40 °C
Flow control range	0.2 ... 70 L/min
Flow measuring range	0.0 ... 99 L/min
Control accuracy flow rate (20 °C; 20 L/min; 1 bar)	0.2 ± L/min
Measurement deviation	± 3,3 % at 1 L/min; ± 0,2 % at 70 L/min
In / Outlet connection thread (outside)	M38 x 1,5
Overall dimensions (WxDxH)	627 x 1033 x 1278 mm
Weight	150 kg
Power consumption max.	0.3 kW
Power supply	100-240 V; 50/60 Hz
Power plug	2 Power cords with plug (CEE7/7 and NEMA 5-15P)
Certification	NRTL according to UL 61010-1:2012/R:2023-06, CSA C22.2 No. 61010-1:2012/U3:2023-06, EN 61010-1:2010/A1:2019

Reserve technical changes

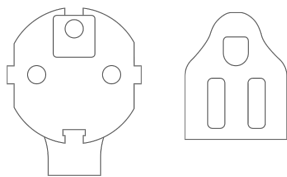

2 Power cords with plug (CEE7/7 and NEMA 5-15P)

LAUDA DR. R. WOBSEY GMBH & CO. KG
Laudaplatz 1 • 97922 Lauda-Königshofen • DE

T + 49 (0) 9343 503-0
info@lauda.de • www.lauda.de
WEEE-Reg-Nr.: DE 66 42 40 57

Kommanditgesellschaft: Sitz Lauda-Königshofen
Registergericht Mannheim • HRA 560069

Persönlich haftende Gesellschafterin:
LAUDA DR. R. WOBSEY Verwaltungs-GmbH
Sitz Lauda-Königshofen
Registergericht Mannheim • HRB 560226

Geschäftsführer:
Dr. Gunther Wobser (Vors.), Dr. Mario Englert,
Dr. Marc Stricker
Beirat: Dr. Gerhard Wobser

PRODUCT DATA SHEET

Published: 2026-03-24

LAUDA filling and flow control system

Based on FD50 / FC80MID, 100-240 V; 50/60 Hz

Part Number: L004011



Reserve technical changes

LAUDA DR. R. WOBSEY GMBH & CO. KG
Laudaplatz 1 • 97922 Lauda-Königshofen • DE

T + 49 (0) 9343 503-0
info@lauda.de • www.lauda.de
WEEE-Reg-Nr.: DE 66 42 40 57

Kommanditgesellschaft: Sitz Lauda-Königshofen
Registergericht Mannheim • HRA 560069

Persönlich haftende Gesellschafterin:
LAUDA DR. R. WOBSEY Verwaltungs-GmbH
Sitz Lauda-Königshofen
Registergericht Mannheim • HRB 560226

Geschäftsführer:
Dr. Gunter Wobser (Vors.), Dr. Mario Englert,
Dr. Marc Stricker
Beirat: Dr. Gerhard Wobser

PRODUCT DATA SHEET

Published: 2026-03-24

LAUDA filling and flow control system

Based on FD50 / FC80MID, 100-240 V; 50/60 Hz

Part Number: L004011

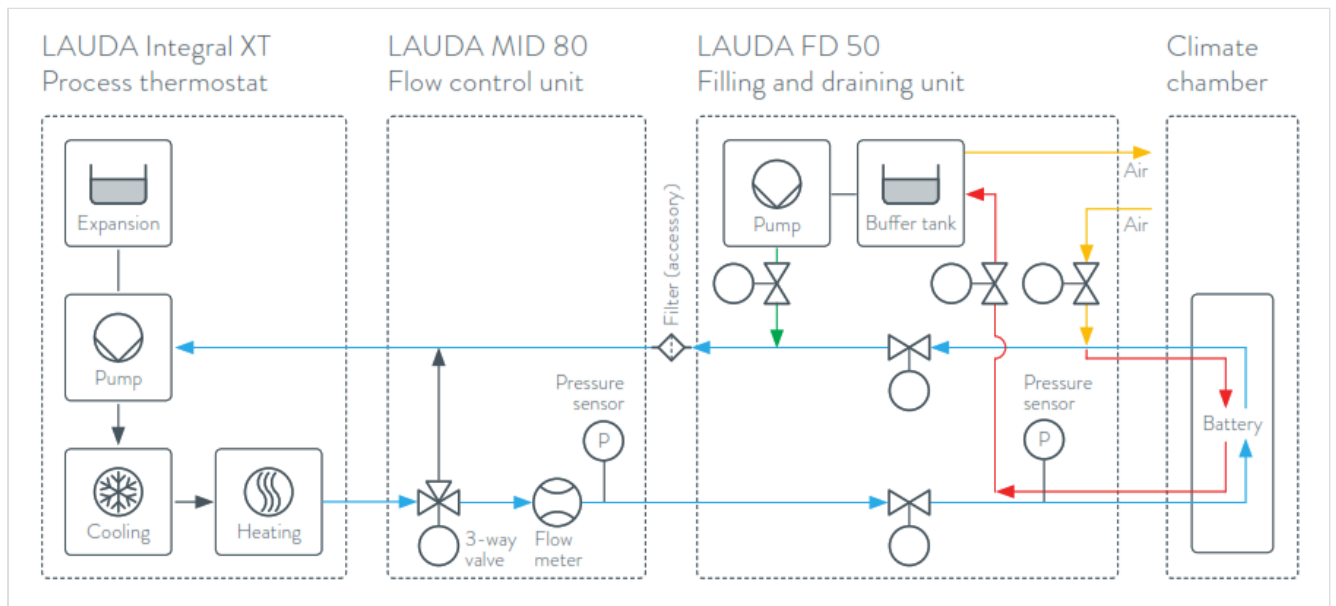

Reserve technical changes

LAUDA DR. R. WOBSEY GMBH & CO. KG
Laudaplatz 1 • 97922 Lauda-Königshofen • DE

T + 49 (0) 9343 503-0
info@lauda.de • www.lauda.de
WEEE-Reg-Nr.: DE 66 42 40 57

Kommanditgesellschaft: Sitz Lauda-Königshofen
Registergericht Mannheim • HRA 560069

Persönlich haftende Gesellschafterin:
LAUDA DR. R. WOBSEY Verwaltungs-GmbH
Sitz Lauda-Königshofen
Registergericht Mannheim • HRB 560226

Geschäftsführer:
Dr. Gunther Wobser (Vors.), Dr. Mario Englert,
Dr. Marc Stricker
Beirat: Dr. Gerhard Wobser