

Operation manual

Interface module LRZ 922 / 923

LRZ 922 – EtherCAT module (M8 connection)

LRZ 923 – EtherCAT module (RJ45 connection)

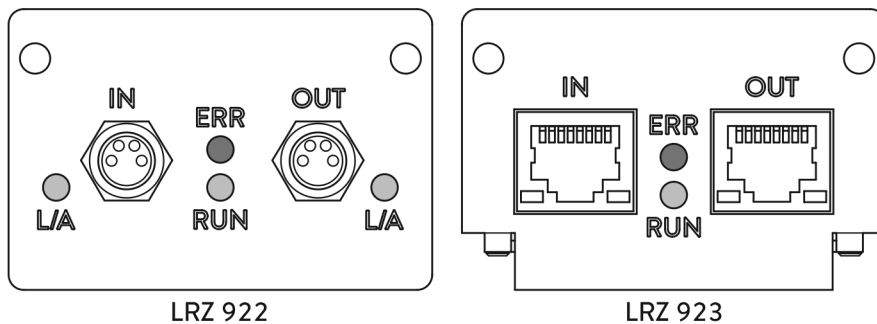

EtherCAT[®]
Conformance tested

Manufacturer:

LAUDA DR. R. WOBSE GMBH & CO. KG

Laudaplatz 1

97922 Lauda-Königshofen

Germany

Telephone: +49 (0)9343 503-0

Fax: +49 (0)9343 503-222

E-mail: info@lauda.de

Internet: <https://www.lauda.de>

Translation of the original operation manual

Q4DA-E.13-018, 2, en_US 25.03.2026 © LAUDA 2021

replaces issue V1R65

Table of contents

1	General.....	5
1.1	Intended use.....	5
1.2	Compatibility.....	6
1.3	Technical changes.....	6
1.4	Warranty conditions.....	6
1.5	Copyright.....	6
1.6	Contact LAUDA.....	7
2	Safety.....	8
2.1	General safety information and warnings.....	8
2.2	Information about the interface module.....	9
2.3	Personnel qualification.....	9
3	Unpacking.....	10
4	Device description.....	11
4.1	What is EtherCAT?.....	11
4.2	Purpose.....	11
4.3	Structure.....	11
4.4	LED status signals.....	12
5	Before starting up.....	14
5.1	Installing the interface module.....	14
5.2	Using the module box.....	16
6	Commissioning.....	17
6.1	Contact assignment.....	17
6.2	Software update.....	18
7	Operation.....	19
7.1	EtherCAT basics.....	19
7.2	Menu structure.....	22
7.3	Interface functions.....	23
7.3.1	Read commands (status).....	23
7.3.2	Write commands (control).....	26
7.3.3	Availability of the interface functions.....	27
7.4	CoE object directory.....	29
7.5	Interaction with the application.....	31
7.5.1	Configuring the safe state.....	31
7.5.2	Value range.....	32
7.5.3	Collective messages.....	32
7.5.4	Time response.....	32
7.5.5	Manual control.....	33

7.6	Interaction with LiBus protocol.....	34
7.6.1	LiBus parameters for the EtherCAT interface (ECM parameters).....	34
7.6.2	LiBus messages to the EtherCAT interface (ECM state).....	35
8	Maintenance.....	36
9	Faults.....	37
9.1	Alarm.....	37
9.2	Error.....	37
9.3	Warning.....	38
10	Decommissioning.....	39
11	Disposal.....	40
12	Technical data.....	41
13	Index.....	42

1 General

Many types of LAUDA constant temperature equipment have vacant module slots for installing additional interfaces. The number, size and arrangement of the module slots vary depending on the device and are described in the operating manual accompanying the constant temperature equipment. Two additional module slots available as accessories can be fitted to a LiBus module box, which is then connected as an external casing to the LiBus interface on the constant temperature equipment.

This operating manual describes how to install and configure the following interface modules:

- EtherCAT module (M8 connection), catalog no. LRZ 922
- EtherCAT module (RJ45 connection), catalog no. LRZ 923

The EtherCAT interface is designed for activating constant temperature equipment using the EtherCAT command set. The interface functions provided for this purpose are described in chapters ↗ Chapter 7.3.1 “Read commands (status)” on page 23 and ↗ Chapter 7.3.2 “Write commands (control)” on page 26.

1.1 Intended use

The interface module can only be operated as intended and under the conditions specified in this operating manual.

The interface module is an accessory that increases the connections options of LAUDA constant temperature equipment. It may only be installed in constant temperature equipment that supports the interface provided. Refer to the chapter “Compatibility” in this operating manual for a list of compatible product lines.

Operation of the interface module is also permitted in combination with the LiBus module box (LAUDA catalog no. LCZ 9727). This operating manual also contains a description of how to install and connect up the module box.

Reasonably foreseeable improper use

- Operation after incomplete assembly
- Operation on incompatible constant temperature equipment
- Operation using cables or connections that are defective or do not confirm to standards

1.2 Compatibility

The interface module is available as an accessory for the following LAUDA product lines:

- ECO
- Integral XT
- Integral IN
- PRO
- Proline
- Variocool
- Variocool NRTL
- Universa



No operation of interfaces of the same type

Only one EtherCAT type interface can be used for each item of constant temperature equipment. This applies irrespective of the interface type.

1.3 Technical changes

All technical modifications are prohibited without the written consent of the manufacturer. Damage resulting from a failure to observe this condition will void all warranty claims.

However, LAUDA reserves the right to make general technical modifications.

1.4 Warranty conditions

LAUDA grants a standard warranty of one year.

1.5 Copyright

This operating manual was written in German, checked and approved. If the content of other language editions deviates from the German edition, the information in the German edition shall take precedence. If you notice any discrepancies in the content, please contact LAUDA Service, see  Chapter 1.6 “Contact LAUDA” on page 7.

Company and product names mentioned in the operating manual are usually registered trademarks of the respective companies and are therefore subject to brand and patent protection. Some of the images used may also show accessories that are not included in the delivery.

All rights reserved, including those relating to technical modifications and translations. This operating manual or parts thereof may not be modified, translated or used in any other capacity without the written consent of LAUDA. Violation of this may obligate the violator to the payment of damages. Other claims reserved.

1.6 Contact LAUDA

Contact the LAUDA Service department in the following cases:

- Troubleshooting
- Technical questions
- Ordering accessories and spare parts

Please contact our sales department for questions relating to your specific application.

Contact information

LAUDA Service

Phone: +49 (0)9343 503-350

Fax: +49 (0)9343 503-283

Email: service@lauda.de

2 Safety

2.1 General safety information and warnings



- Read this operating manual carefully before use.
- Keep the operating manual in a place within easy reach of the interface module.
- This operating manual is part of the interface module. If the interface module is passed on, the operating manual must be kept with it.
- This operating manual is applicable in combination with the operating manual of the constant temperature equipment in which the interface module is installed.
- Manuals for LAUDA products are available for download on the LAUDA website: <https://www.lauda.de>
- The warnings and safety instructions in this operating manual must be observed without fail.
- There are also certain requirements for personnel, see ↗ Chapter 2.3 “Personnel qualification” on page 9.

Structure of warnings

Warning signs	Type of danger
	Warning – danger zone.
Signal word	Meaning
DANGER!	This combination of symbol and signal word indicates an imminently dangerous situation that will result in death or serious injury if it is not avoided.
WARNING!	This combination of symbol and signal word indicates a potentially dangerous situation that can result in death or serious injury if it is not avoided.
NOTICE!	This combination of symbol and signal word indicates a potentially dangerous situation that can result in material and environmental damage if it is not avoided.

2.2 Information about the interface module

- Always disconnect the constant temperature equipment from the power supply before installing the interface module or connecting interfaces.
- Always take the recommended safety measures against electrostatic discharge before handling interface modules.
- Avoid touching the circuit board with metallic tools.
- Do not start up the constant temperature equipment before installation of the interface module is complete.
- Store any unused interface modules in their packaging in accordance with the specified ambient conditions.
- Use only suitable cables of sufficient length for cable connections.
- Make sure that the protective screen on the cables and connectors complies with EMC regulations. LAUDA recommends using pre-assembled cables.
- Always lay cables correctly so that they do not pose a tripping hazard. Secure the laid cables and make sure that they cannot be damaged during operation.
- Check the condition of the cables and interfaces prior to each operation.
- Immediately clean any soiled parts, in particular unused interfaces.
- Make sure that the signals transmitted via the interface correspond to the permitted operating parameters of the interface module.

2.3 Personnel qualification

Specialized personnel

Only specialized personnel are permitted to install interfaces modules. Specialized personnel are personnel whose education, knowledge, and experience qualify them to assess the function and risks associated with the device and its use.

3 Unpacking



DANGER! Transport damage

Electric shock

- Closely inspect the device for transport damage prior to commissioning!
- Never operate a device that has sustained transport damage!



NOTICE! Electrostatic discharge

Material damage

- Always observe safety measures against electrostatic discharge.

Please observe the following installation sequence:

1. Remove the interface module from its packaging.
2. If you want to store the interface module at the installation location, use the outer packaging. This packaging is protected against static charging.
3. After installing the equipment, dispose of the packaging materials in line with environmental regulations, see ↪ “Packaging” on page 40.



If you discover any damage on the interface module, contact LAUDA Service immediately, see ↪ Chapter 1.6 “Contact LAUDA” on page 7.

4 Device description

4.1 What is EtherCAT?

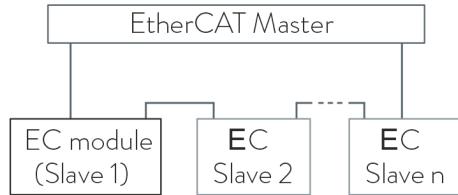

Fig. 1: Overview of EtherCAT

EtherCAT is an Ethernet-based field bus with master/slave functionality.

The protocol properties of EtherCAT achieve an efficient, synchronous data throughput. The network characteristics of Ethernet allow multiple slave devices to be integrated in a network. Different network topologies are supported, including the CAN bus fieldbus system (Controller Area Network). With the CoE protocol (CANopen over EtherCAT), EtherCAT provides the same communication mechanisms familiar from CANopen devices, thereby allowing the implementation of test bench measuring applications controlled via the EtherCAT master.

4.2 Purpose

The EtherCAT module is designed for installation in constant temperature equipment that supports the EtherCAT interface. The EtherCAT interface enables constant temperature equipment to be controlled using the EtherCAT command set.

4.3 Structure



Refer to [Chapter 6.1](#) “Contact assignment” on page 17 for more information on contact assignment.

EtherCAT module (M8 connection)

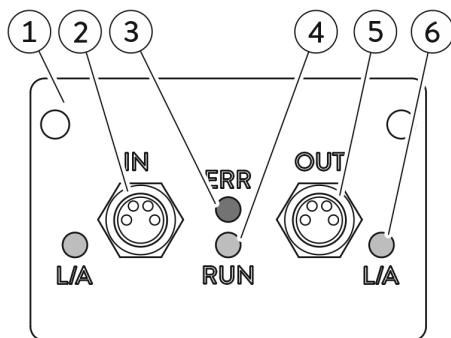

Fig. 2: EtherCAT module LRZ 922

The signal input (*IN*) and signal output (*OUT*) are integrated in the interface module by way of two robust 4-pin M8 sockets specially designed for industrial environments.

- 1 Cover with holes for fastening screws
- 2 Signal input *IN*, M8 socket, 4-pin
- 3 Red *ERR* LED: Indicates that malfunctions have occurred.
- 4 Green *RUN* LED: Indicates the operating status of the interface.
- 5 Signal output *OUT*, M8 socket, 4-pin
- 6 Green *L/A* LED (2x): Indicates whether the associated interface is connected and whether data is being transmitted (link/activity).

EtherCAT module (RJ45 connection)

The signal input (*IN*) and signal output (*OUT*) are integrated in the interface module by way of two robust RJ45 sockets. The interface module is designed for use in a clean, dry environment and connected using standard Ethernet cables.

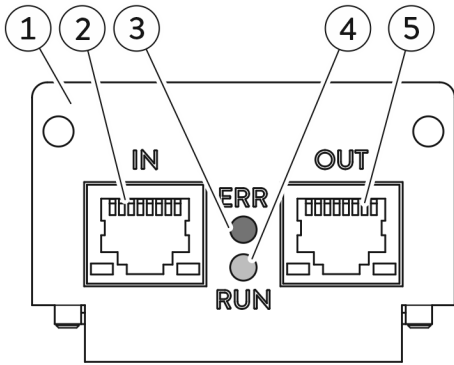

- 1 Cover with holes for fastening screws
- 2 Signal input *IN*, RJ45 connection *
- 3 Red *ERR* LED: Indicates that malfunctions have occurred.
- 4 Green *RUN* LED: Indicates the operating status of the interface.
- 5 Signal output *OUT*, RJ45 connection *

* The green LED on the RJ45 connection indicates whether the interface is connected and whether data is being transmitted (link/activity).

Fig. 3: EtherCAT module LRZ 923

4.4 LED status signals

Red *ERR* LED

The red *ERR* LED indicates that malfunctions have occurred. If several malfunctions occur around the same time, the error that was detected first is signaled.

LED signal	Fault	Description	Example
Off	No fault	EtherCAT communication is functioning correctly.	
Flashing	Invalid configuration	A pin access violation was detected, for which the master has specified a change in state.	Change in register or object settings, invalid hardware configuration, etc.
Single flash	Local error	A locally occurring error causes the application of the slave device to change the EtherCAT state. The bit error display in the AL status register is set to 1.	Synchronization or input error (EtherCAT state changes from <i>Op</i> to <i>SafeOpError</i> .)
Double flash	EtherCAT / process data timeout (watchdog timeout)	The expected response was not received within the expected time frame.	Sync Manager watchdog timeout

Green *RUN* LED

The green *RUN* LED indicates the operating status of the interface controlled by the EtherCAT State Machine (ESM), see ↪ “EtherCAT operating statuses” on page 22.

LED signal	EtherCAT operating status	Brief description
Off	<i>Init</i> (initialization)	Preparation
Flashing	<i>Pre-Op</i> (pre-operational)	Operational preparation
Single flash	<i>Safe-Op</i> (safe operational)	Operational security
On	<i>Op</i> (Operational)	Communication mode

Green *L/A* LED

The green *L/A* LED indicates whether the interface is connected and whether data is being transmitted (link/activity).

LED signal	Description
Off	The interface is not connected.
On	The interface is connected and inactive.
Flashing	The interface is connected; data is being transmitted.

5 Before starting up

5.1 Installing the interface module

The interface module is connected to an internal LiBus ribbon cable and inserted into a vacant module slot. The number and arrangement of the module slots vary depending on the device. The module slots are protected by a cover that is screwed onto the casing or attached to the slot opening.



WARNING!
Touching live parts

Electric shock

- Disconnect the device from the power supply before starting any installation work.
- Always observe safety measures against electrostatic discharge.



The module installation description essentially applies to all LAUDA constant temperature equipment; the example diagrams here show the installation of an analog module in constant temperature equipment from the Variocool product line.

Please note that an interface module with a small cover can only be installed in a low module slot. The fitted cover must cover the opening on the module slot completely.

You will require two M3 x 10 screws and a suitable screwdriver to secure the interface module.

Please observe the following installation sequence:

1. Turn off the constant temperature equipment and pull out the mains plug.
2. If necessary, remove the screws from the cover on the relevant module slot. If necessary, use a slotted screwdriver to prise off the cover.

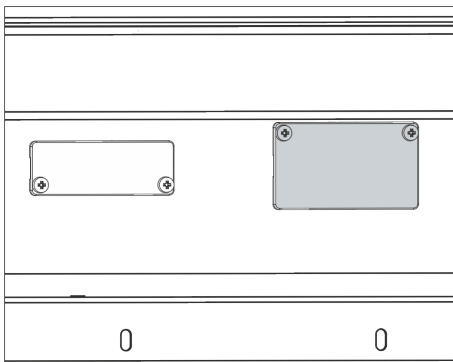

Fig. 4: Removing the cover (schematic diagram)

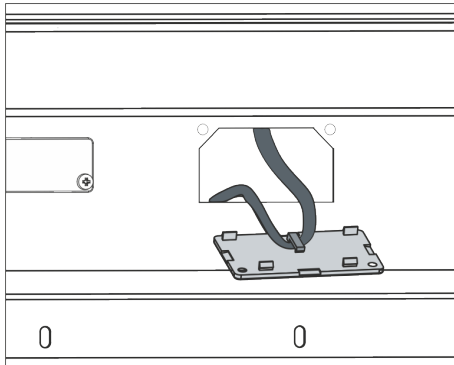

Fig. 5: Detaching the LiBus ribbon cable (schematic diagram)

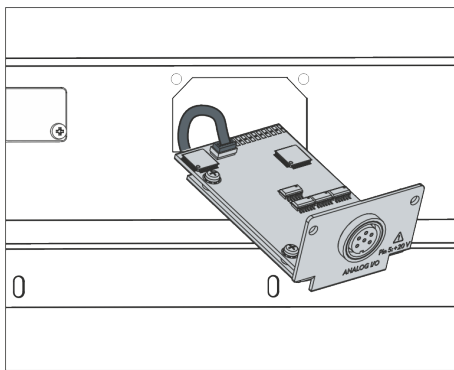

Fig. 6: Connecting the interface module (schematic diagram)

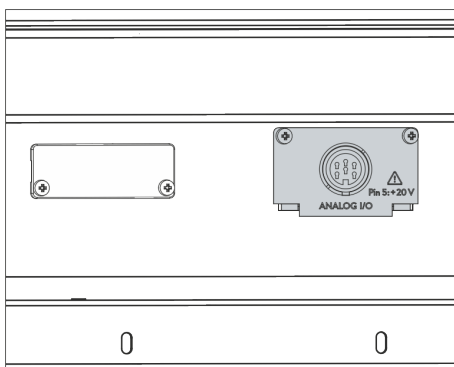

Fig. 7: Securing the cover (schematic diagram)

3. Remove the cover from the module slot.
 - ▶ The module slot is open. The LiBus ribbon cable is attached to the inside of the cover and is easily accessible.
4. Disconnect the LiBus ribbon cable from the cover.
5. Connect the red plug on the LiBus ribbon cable to the red socket on the circuit board of the interface module. Plug and socket are reverse polarity protected: Make sure that the lug on the plug is aligned with the recess in the socket.
 - ▶ The interface module is correctly connected to the constant temperature equipment.
6. Slide the LiBus ribbon cable and the interface module into the module slot.
7. Secure the cover to the casing using two M3 x 10 screws.
 - ▶ The new interface on the constant temperature equipment is ready for operation.

5.2 Using the module box

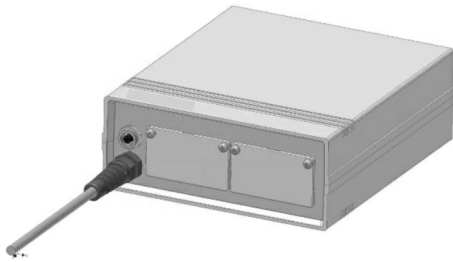

Fig. 8: LiBus module box, catalog no. LCZ 9727

You can extend LAUDA constant temperature equipment by two additional module slots using the LiBus module box. The module box is designed for interface modules with a large cover and is connected to constant temperature equipment via a vacant LiBus socket. The socket on the constant temperature equipment bears the label **LiBus**.

Please observe the following installation sequence:

1. Switch off the constant temperature equipment.
2. Disconnect the cable on the module box from the constant temperature equipment.
 - ▶ The module box is disconnected from the power supply.
3. Check which interfaces are already present on the constant temperature equipment and module box.



Observe the information on interface module compatibility. Only install an interface module with the same type of interface if operation with several of these interfaces is permitted.

4. Install the required interface module in the module box. Please read the information on installing the module box in the constant temperature equipment, see chapter "Installing the interface module".
5. Position the module box close to the constant temperature equipment.
6. Connect the cable on the module box to the LiBus socket on the constant temperature equipment.
 - ▶ The interfaces on the module box are ready for operation.

6 Commissioning

6.1 Contact assignment



Please read this contact assignment information if you have assembled the cables yourself. Always use shielded connection lines and connect the protective screen to the connector shell.

EtherCAT with M8 connection

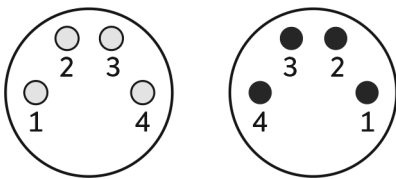

Fig. 9: M8 contacts on socket / plug

The two M8 connections on the EtherCAT interface are designed as 4-pin round connectors with a screw connection. The contacts are arranged according to IEC 61918, Annex H.

Table 1: M8 contact assignment

Contact	Signal	Function
1	TD+	Transmitted data +
2	RD+	Received data +
3	RD-	Received data -
4	TD-	Transmitted data -
Casing	Shield	Shield

EtherCAT with Ethernet connection

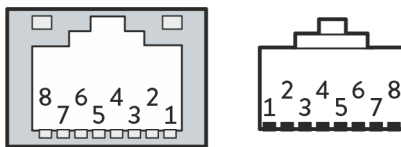

Fig. 10: RJ45 contacts on socket / plug

The Ethernet version of the Ethernet interface is equipped with standard type RJ45 sockets (8P8C modular plugs according to CFR Part 68). Standard Ethernet cables that correspond to category CAT5e or higher (8P8C assignment with twisted pairs) must be used for the connection.

Table 2: RJ45 contact assignment

Contact	Signal	Function
1	TD+	Transmitted data +
2	RD+	Received data +
3	RD-	Received data -
4	-	
5	-	
6	TD-	Transmitted data -
7	-	
8	-	
Casing	Shield	Shield

6.2 Software update

Older software installed on constant temperature equipment may have to be updated for the new interface to work.

1. Switch on the constant temperature equipment after installing the new interface.
2. Check whether a software warning appears on the display:
 - Warning *SW too old*: Please contact LAUDA Service, see  Chapter 1.6 “Contact LAUDA” on page 7.
 - No software warning: Operate the constant temperature equipment as normal.

7 Operation

7.1 EtherCAT basics

Abbreviations

Abbreviation	Meaning
CAN	Controller Area Network
CoE	CANopen over EtherCAT
DPR	Dual Port RAM
EC	EtherCAT
ECM	EtherCAT module
ERR	Error
ESC	EtherCAT Slave Controller
ESI	EtherCAT Slave Information
ESM	EtherCAT State Machine
FMMU	Field Bus Memory Management Unit
I/O	Input/Output
L/A	Link/Activity
LiBus	LAUDA Internal Bus
PDI	Process Data Interface
RO Read Only	Read Only
RW	Read and Write
SW	Software



* Based on the EtherCAT standard, the terms *Input*, *Output*, *Read* and *Write* are always used here from the perspective of the **EtherCAT master**. For example, *Output* and *Write* describe the data transfer from the master to the slave.

Identifier

The following identifiers have been defined to clearly identify the EtherCAT interface:

Vendor ID: - 0000058Bh

Vendor Name: - LAUDA DR. R. WOBSE R. GMBH & CO. KG-

Product group: - LAUDA-A-Product-Group

Group ID: - 2

Product name: - LAUDA-A

Product code: - 3

Device The external interface of the ECM is an EtherCAT slave interface. The ECM is considered a "complex device" according to the EtherCAT standard because it incorporates an integral microcontroller.

Ports The EtherCAT interface is equipped with two physical ports of the Ethernet 100Base-TX type:

- Input (*IN*): EtherCAT port 0
- Output (*OUT*): EtherCAT port 1

The EtherCAT ports are optionally designed as *M8* type sockets (according to IEC 61076-2-104) or *RJ45*.

Local addresses The following local address areas are defined on the constant temperature equipment (EtherCAT slave):

Local IP address	Bytes used	Memory
0x0000		ESC register
0x1000	128	Write mailbox data
0x1400	128	Read mailbox data
0x1800	10	Write process data
0x1C00	30	Read process data

Sync Manager A total of 4 Sync Managers are used on the EtherCAT slave controller:

- *SM0*, *SM1*: Reading and writing mailbox data for operating the CoE application protocol
- *SM2*, *SM3*: Reading and writing the process data

The following assignment is defined according to the EtherCAT standard:

Sync Manager	Use	Type	Local IP address	Byte length
SM0	Write mailbox data	1 buffer, write	1000h	128
SM1	Read mailbox data	1 buffer, read	1400h	128
SM2	Write process data	3 buffer, write	1800h	10
SM3	Read process data	3 buffer, read	1C00h	30
SM4 – SM7	<i>unused</i>			

Field Bus Memory Management Units

The FMMUs are functional units in the EtherCAT slave controller of the EtherCAT slaves. They are responsible for converting the logical EtherCAT addressing, which is specific to the EtherCAT master, into the local addressing of the EtherCAT slave. The following FMMUs are defined:

FMMU	Use	Type	Local IP address	Byte length
FMMU0	Read process data	read	1C00.0h	240
FMMU1	Write process data	write	1800.0h	80
FMMU2	Read mailbox data	read	080D.0h	1
FMMU3 – FMMU7	<i>unused</i>			

Distributed Clock

The EtherCAT function "Distributed Clock" is not used.

Application protocols

The CoE (CANopen over EtherCAT) protocol is used for communicating mailbox data, for example, for version numbers, serial numbers and parameter information. CoE is also used to structure the process data (object directory).

Firmware is updated via LiBus using the update function of the constant temperature equipment. Other protocols predefined in the EtherCAT standard are not used.

EtherCAT EEPROM

The first block containing 8 words (16 bits each) can be partially written. Everything else is read only. If the master attempts to write in read-only areas, the request is simply rejected.

In the first block, the following data fields are defined as writable:

1. - Word address 0, PDI Control, Bit 9: Enhanced Link Detection
2. - Word address 4, entire word: Configured Station Alias
3. - Word address 7, entire word: Checksum

EtherCAT operating statuses

A distinction is drawn between 4 EtherCAT interface operating states on the constant temperature equipment (EtherCAT slave):

slave operating status *	Description
<i>Init</i> (initialization)	Preparation: The constant temperature equipment can be controlled manually. Communication is not possible, the Sync Manager channels for mailbox communication are being initialized.
<i>Pre-Op</i> (pre-operational)	Operational preparation: The constant temperature equipment can be controlled manually. The process data communication channels are initialized and all required settings are transferred through mailbox communication.
<i>Safe-Op</i> (safe operational)	Operational security: The configured safety parameters are used, see Chapter 7.5.1 “Configuring the safe state” on page 31. Mailbox and process data communication are possible, incoming data is updated periodically. The output data of the constant temperature equipment is not yet transferred to the EtherCAT master in this secure state.
<i>Op</i> (operational)	Communication mode: The constant temperature equipment cannot be controlled manually. In the first step, the EtherCAT slave provides data in the form of output data that it previously received from the EtherCAT master. As a result, the EtherCAT master activates communication mode and the constant temperature equipment can transmit current output data.

7.2 Menu structure



The menu only ever shows functions that are available for the current constant temperature equipment.

The menu for configuring the interface is integrated in the main menu of the relevant constant temperature equipment:

Menu → *Modules* → *EtherCAT*

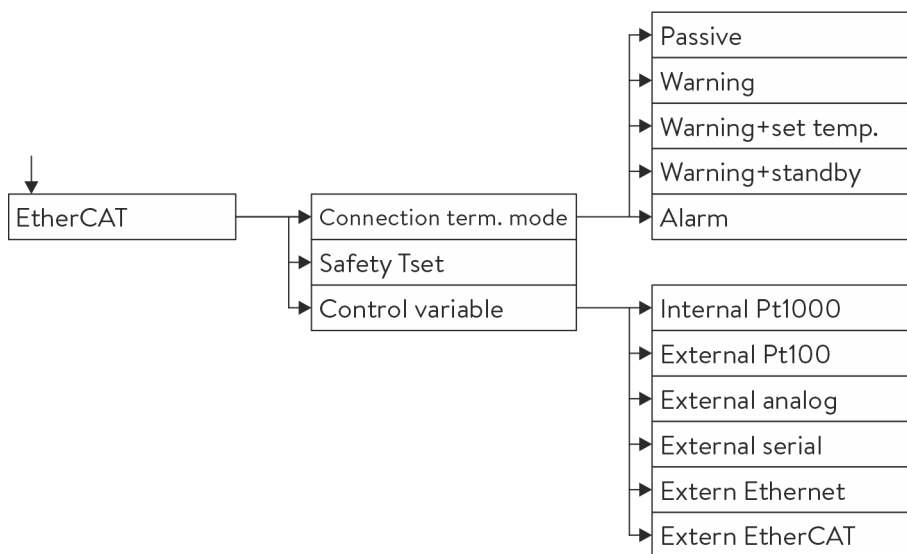

Fig. 11: EtherCAT interface menu

7.3 Interface functions

Interface functions such as read and write commands make it possible to read out the current operating parameters of constant temperature equipment and predefine specific settings and process values.

The interface functions supported by this interface are presented briefly below. They are sorted by topic according to the component affected and assigned a unique ID. Depending on the technical configuration of your constant temperature equipment, the number and scope of the interface functions actually available may vary from the list shown here, see chapter "Availability of the interface functions".

EtherCAT process data

In order to make meaningful use of the EtherCAT standard, all read data (RO, Read Only) and write data (RW) should be stored in series without gaps in the process data memory of the slave. An alignment to 16 bit limits must be inserted at the end of the respective data block.



All EtherCAT interface write data is classified as not relevant to safety in the constant temperature equipment. This specification and its implementation do not guarantee safe behavior, irrespective of the fact that the state Safe op is implemented and safe values are configured.

7.3.1 Read commands (status)

The EtherCAT module recognizes the following read commands, which you can use to query the operating data of the constant temperature equipment:

Table 3: Temperature

ID	Function	Local IP address	Bit length	Data field name	Data type	[Unit], value range
2	Temperature set point	1C00.0h	32	Set Temperature	s32	[0.001 °C]
3	Bath temperature (outflow temperature)	1C0E.0h	32	Temperature Internal	s32	[0.01 °C]
4	Bath temperature (outflow temperature)	1C0E.0h	32	Temperature Internal	s32	[0.001 °C]
5	Controlled temperature (internal / external Pt / external analog / external serial)	1C12.0h	32	Temperature External	s32	[0.001 °C]
16	External temperature TE (Pt)	1C04.0h	32	Actual Temperature External	s32	[0.001 °C]
25	Overtemperature turn off point T_Max	1C16.0h	16	T_Max	s16	[0.1 / 1 °C]
27	Limitation of outflow temperature TiH (upper limit)	1C0A.0h	16	TiH	s16	[0.1 °C]

ID	Function	Local IP address	Bit length	Data field name	Data type	[Unit], value range
29	Limitation of outflow temperature TiH (lower limit)	1C08.0h	16	TiL	s16	[0.1 °C]
33	Temperature set point Tset in safe mode	1C19.0h	32	Set Temperature Safe Value	s32	[0.001 °C]

Table 4: Fill level

ID	Function	Local IP address	Bit length	Data field name	Data type	[Unit], value range
9	Bath level (fill level)	1C18.0	8	Level	u8	[-], 0 – 20

Table 5: Rights

ID	Function	Local IP address	Bit length	Data field name	Data type	[Unit], value range
63	Status of keyboard Master: 0 = free / 1 = blocked	1C0D.1h	1	Keyboard lock	bit	[-], 0 / 1

Table 6: Control

ID	Function	Local IP address	Bit length	Data field name	Data type	[Unit], value range
67	Control in control variable X: 0 = internal / 1 = external Pt / 2 = external analog / 3 = external serial / 5 = external Ethernet / 6 = external EtherCAT	1C0C.0h	8	External Sensor Selector	bit	[-], 0 – 6

Table 7: Status

ID	Function	Local IP address	Bit length	Data field name	Data type	[Unit], value range
137	Error status	1C1E.0h	1	Collective fault	bit	[-], 0 / 1
138	Alarm status	1C1A.0h	24	Alarm flags	Bit field	
139	Warning status	1C1A.0h	1	Collective warning	bit	[-], 0 / 1

Table 8: Safety

ID	Function	Local IP address	Bit length	Data field name	Data type	[Unit], value range
144	Connection Loss Mode: Operating mode in "Safe op" state	1C18.0h	8	Operating mode in "Safe op" state	s8	[-], 0 – 4
146	External Sensor Selector Safe Value: Safe value for actual external temperature value (via interface)	1C1D.0	8	External Sensor Selector Safe Value	s8	[-], 0 – 6
147	Safe value for TiL	1C1E.0h	16	Safe value for TiL	s16	0 °C
149	Safe value for TiH	1C20.0h	16	Safe value for TiH	s16	90 °C

7.3.2 Write commands (control)

The EtherCAT module recognizes the following write commands, which you can use to transfer values to the constant temperature equipment:

Table 9: Temperature

ID	Function	Local IP address	Bit length	Data field name	Data type	[Unit], value range
1	Temperature set point	1800.0h	32	Set Temperature	s32	[0.001 °C]
15	Actual value of external temperature (via interface)	1804.0h	32	Actual Temperature External	s32	[0.001 °C]
26	Limitation of outflow temperature TiH (upper limit)	180A.0h	16	TiH	s16	[0.1 °C]
28	Limitation of outflow temperature TiH (lower limit)	1808.0h	16	TiL	s16	[0.1 °C]

Table 10: Rights

ID	Function	Local IP address	Bit length	Data field name	Data type	[Unit], value range
62	Keyboard Master (equivalent to "KEY"): 0 = unlock / 1 = lock	180D.1h	1	Keyboard lock	bit	[-], 0 / 1

Table 11: Control

ID	Function	Local IP address	Bit length	Data field name	Data type	[Unit], value range
66	Control in control variable X: 0 = internal / 1 = external Pt / 2 = external analog / 3 = external serial / 5 = external Ethernet / 6 = external EtherCAT	180C.0h	8	External Sensor Selector	u8	[-], 0 – 6

Table 12: Status

ID	Function	Local IP address	Bit length	Data field name	Data type	[Unit], value range
74	Switch equipment on / off (standby)	180D.0h	1	Power On	bit	[-], 0 / 1

7.3.3 Availability of the interface functions

The following table shows the read and write commands that the interface module provides for all compatible product lines of constant temperature equipment.



Special functions are only available if the constant temperature equipment is equipped accordingly. Optional accessories may have to be connected correctly and ready for operation.

ID	Universa	Integral IN		Variocool		PRO	ECO	Proline, Proline Kryomats	Integral XT*
		✓	IN...T*	VC NRTL	VC				
1	✓	✓	✓	✓	✓	✓	✓	✓	✓
2	✓	✓	✓	✓	✓	✓	✓	✓	✓
3	–	–	–	–	✓	–	✓	✓	✓
4	✓	✓	✓	✓	–	✓	–	–	–
5	✓	✓	✓	✓	✓	✓	✓	✓	✓
9	✓**	✓	✓	✓	✓	✓	✓	✓	✓
15	✓	✓	✓	✓	✓	✓	✓	✓	✓
16	✓	✓	✓	✓	✓	✓	✓	✓	✓
25	✓	✓	✓	✓	✓	✓	✓	✓	✓
26	✓	✓	✓	✓	✓	✓	✓	✓	✓
27	✓	✓	✓	✓	✓	✓	✓	✓	✓
28	✓	✓	✓	✓	✓	✓	✓	✓	✓
29	✓	✓	✓	✓	✓	✓	✓	✓	✓
33	✓	✓	✓	✓	✓	✓	✓	✓	✓
62	✓	✓	✓	✓	✓	✓	✓	✓	✓
63	✓	✓	✓	✓	✓	✓	✓	✓	✓
66	✓	✓	✓	✓	✓	✓	✓	✓	✓
67	✓	✓	✓	✓	✓	✓	✓	✓	✓
74	✓	✓	✓	✓	✓	✓	✓	✓	✓
75	✓	✓	✓	✓	✓	✓	✓	✓	✓
137	✓	✓	✓	✓	✓	✓	✓	✓	✓
138	✓	✓	✓	✓	✓	✓	✓	✓	✓
139	✓	✓	✓	✓	✓	✓	✓	✓	✓
144	✓	✓	✓	✓	✓	✓	✓	✓	✓

* Equipment type as per rating label

** only at Universal MAX

ID	Universa	Integral IN		Variocool		PRO	ECO	Proline, Proline Kryomats	Integral XT*
		✓	IN...T*	VC NRTL	VC				
146	✓	✓	✓	✓	✓	✓	✓	✓	✓
147	✓	✓	✓	✓	✓	✓	✓	✓	✓
149	✓	✓	✓	✓	✓	✓	✓	✓	✓

* Equipment type as per rating label

** only at Universal MAX

7.4 CoE object directory

Communication between the EtherCAT master and the constant temperature equipment is based on the standard CoE (CANopen over EtherCAT) protocol. The CANopen objects used are created in an EtherCAT interface object directory and are described below.



The EtherCAT interface is a "Module Device" within the meaning of the EtherCAT standard. With this extremely simple form of device, all modules are defined statically. The objects are all RO (read only) type objects, which means that the EtherCAT master can read the object description but cannot modify it. The EtherCAT master must therefore use the available process data according to the definition specified on the module.

Object index	Object name	Data type	Value	Description
1000h	Device Type	u32	04561389h	CoE device type: LWord: Modular Device Profile: 5001 HWord: Module Profile Number: 1110
1008h	Device Name	str	"LAUDA-A"	Device name
1009h	Hardware Version	str	"x.yy"	Hardware version number (variable, starting with "1.01")
100Ah	Software Version	str	"x.yy"	Software version number (variable, starting with "1.01")
1018h	Identity [4]			Unique device identifier
	Vendor ID	u32	0000058Bh	"LAUDA" Vendor ID
	Product Code	u32	00000003h	"LAUDA-A" Product Code
	Revision	u32	00010001h	"LAUDA-A" Revision
	Serial Number	u32		Serial number, sequential
1600h	Control	u32 []	7000xxxxh	Mapping objects: The content of these objects refers to the individual data object fields. Structure and content are therefore derived from the data definition of the respective process.
1A00h	Status	u32 []	6000xxxxh	
1A01h	Safe Values	u32 []	6010xxxxh	
1C00h	Sync Manager Types [4]			Type assignment for Sync Manager
		u8	01h	SM0 = Write mailbox
		u8	02h	SM1 = Read mailbox
		u8	03h	SM2 = Write process data
		u8	04h	SM3 = Read process data
1C12h	Sync Manager Write Assign [1]			SM2: List of all mapping objects of the "Write" type

Object index	Object name	Data type	Value	Description
		u16	1600h	Reference to "Control"
1C13h	Sync Manager Read Assign [2]			SM3: List of all mapping objects of the "Read" type
		u16	1A00h	Reference to "Status"
		u16	1A01h	Reference to "Safe Values"
1C32h	Sync Manager Write Data [1]			SM2: Parameter
	Sync Mode	u16	0	<i>not synchronized</i>
1C33h	Sync Manager Read Data [1]			SM3: Parameter
	Sync Mode	u16	0	<i>not synchronized</i>
6000h	Status			Data objects: The data types are derived from the definition of the respective process data; the values are the process data.
6010h	Safe Values			
7000h	Control			
9000h	Control Info [4]			Minimum and maximum permitted values for the write data of the "Control" group.
	Set Temperature MIN	s16	dynamic	
	Set Temperature MAX	s16	dynamic	
	External Sensor Selector MIN	u8	static	
	External Sensor Selector MAX	u8	static	
	Til MIN	s16	dynamic	Limitation of outflow temperature TiH (lower limit)
	Til MAX	s16	dynamic	
	Tih MIN	s16	dynamic	Limitation of outflow temperature TiH (upper limit)
	Tih MAX	s16	dynamic	
F000h	Modular Device Profile [2]			
	Module Index Distance	u16	10h	Index distance between modules
	Maximum Number of Modules	u16	1	Number of modules

7.5 Interaction with the application

7.5.1 Configuring the safe state

The safe state *Safe op* of the EtherCAT protocol is defined for cases where communication between the master and slave is interrupted. If an interruption occurs, all output values of the EtherCAT slave are set to safe values. These safe values can only be defined in line with the application used to operate the constant temperature equipment. They must be predefined on the constant temperature equipment prior to starting up.

The EtherCAT protocol distinguishes between 5 different operating modes that are defined for the behavior in the safe state in the event of an interruption in communication:

Table 13: Behavior in the safe state

<i>Safe op</i> action	Operating mode (Connection Loss Mode)				
	Passive	Warning	Safe	Standby	Alarm
Switch off constant temperature equipment ("standby")	---	---	---	1	---
Set all control parameters to the defined safe values, see Chapter 7.6.1 "LiBus parameters for the EtherCAT interface (ECM parameters)" on page 34.	---	---	Safe value	---	---
Report "Connection Loss" warning	0	1	1	1	0
Trigger "Connection Loss" alarm	0	0	0	0	1

In the safe state, data parameters cannot be changed locally on the device, but only through access via the interface. Changes to a safety parameter ("Connection Loss Mode") or a defined safe value are always adopted immediately. In the safe state, modified values become active immediately.

Table 14: Type of safe values predefined for write parameters

Write parameter	Safe value	Note on safe state
Set Temperature	dynamic	SAFE_OP_T_SET parameter
Actual Temperature External	–	Sensor value is not transmitted.
External Sensor Selector	dynamic	SAFE_OP_EXT_SENS_SEL parameter
Power On	–	Depending on the operating mode (Connection Loss Mode, see table above).

7.5.2 Value range

The valid value range for write data may be restricted. The EtherCAT interface provides the minimum and maximum values of all restricted write data in the "Control Info" CoE object (object index 9000h), see [Chapter 7.4 "CoE object directory"](#) on page 29.

If the EtherCAT master sets invalid values, the constant temperature equipment will react as follows:

- The previously set value continues to apply; invalid values are ignored.
- The EtherCAT interface reports the warning "Set Out of Range", see [Further information on page 35](#).

As soon as the EtherCAT master sets a valid value, the warning disappears and the constant temperature equipment applies the new value.

7.5.3 Collective messages

The "Error" and "Warning" data fields in the process data group of the read data must each be regarded as a collective message.

The EtherCAT interface uses OR links to summarize the error messages and warnings that occur, and then outputs the result as a collective error or collective warning.

7.5.4 Time response

The internal latency times of the EtherCAT interface are less than 100 ms. This value applies to data transmission in the write and read directions, whereby any other influences from physical media involved in the transmission process are not taken into consideration.

This leads to the following effects, which must be taken into account during the process control phase:

- The EtherCAT master must maintain a minimum time interval of 100 ms to send continuously increasing temperature specifications, for example.
- A delay of 2 application cycles corresponding to a time of 2 – 3 ms occurs at the EtherCAT interface between the moment data is written to a write data field and the moment the associated back-read data field is updated.

Data transmission is also delayed when the EtherCAT operating status changes. The EtherCAT master must therefore adhere to the following timeout specifications when controlling the state transitions:

Table 15: Timeout specifications for EtherCAT state transitions

Initiate state	Target state	Transition duration
<i>Init</i>	<i>Pre-Op</i>	2000 ms
<i>Pre-Op</i>	<i>Safe-Op</i>	2000 ms
<i>Safe-Op</i>	<i>Op</i>	100 ms

7.5.5 Manual control

The following table describes the options for manually controlling the constant temperature equipment locally using its control element and depending on the state of the EtherCAT interface.

EC state	Meaning	Behavior
<i>Init, Pre-Op</i>	Initialization	Manual control possible.
<i>Safe-Op</i>	Safety mode	<p>The manual control options depend on the operating mode (CLM parameters):</p> <ul style="list-style-type: none"> ■ "Passive", "Warning" operating modes: Manual control possible. ■ "Safe" operating mode: The temperature can be controlled by the safe value ("Set Temperature Safe Value" parameter). <p>In order to activate the <i>Init</i> state and obtain full access via the command / terminal, you must switch the control off and on again.</p> <p>If you have the necessary user rights, you can also set "Passive" operating mode as an alternative (processed dynamically by the ECM).</p>
<i>Op</i>	Normal operation	Manual control not possible.

7.6 Interaction with LiBus protocol

7.6.1 LiBus parameters for the EtherCAT interface (ECM parameters)

The following table shows all the LiBus parameters that are used in connection with the EtherCAT interface:

Name	ID	Data type	R/W	Description	[Unit], value range
LPNR	0	u32	R	Printed circuit board number of the interface	[-]
VENDORID	1	u32	R	EtherCAT Vendor ID	[-], 0-FFFFFFFFh
PRODUCTCODE	2	u32	R	EtherCAT product code	[-], 0-FFFFFFFFh
REVISIONNR	3	u32	R	EtherCAT revision number	[-], 0-FFFFFFFFh
SERNR	4	u32	R/W	EtherCAT serial number	[-], 0-FFFFFFFFh
U_DC	5	float	R	Voltage 24 V	[0.001 V], 0-39.699 V
CLM	6	u8	R/W	Connection Loss Mode	[-], 0 – 4
SAFE_OP_T_SET	7	s16	R/W	<i>Set Temperature Safe Value</i> : Safe value for the <i>Set Temperature</i> write data field.	[0.001 °C], device-dependent
SAFE_OP_T_MIN	10	s16	R/W	Minimum value for <i>Set Temperature Safe Value</i>	[0.001 °C], device-dependent
SAFE_OP_T_MAX	11	s16	R/W	Maximum value for <i>Set Temperature Safe Value</i>	[0.001 °C], device-dependent
SAFE_OP_EXT_SENS_SEL	12	u8	R/W	<i>External Sensor Selector Safe Value</i> : Safe value for the <i>External Sensor Selector</i> write data field	[-], 0 – 6
SNR_STRING	64 – 69	str [6]	R/W	Serial number string	

Connection Loss Mode

The *CLM* parameter has the following valid values with the specified meanings:

Value	Meaning	Description for state transition to "Safe op"
0	Passive	No actions occur.
1	Warning	Generates the warning <i>Remote Connection Fault</i> .
2	Safe	Generates the warning <i>Remote Connection Fault</i> and sets safe values for <i>Set Temperature</i> .
3	Standby	Generates the warning <i>Remote Connection Fault</i> and switches the constant temperature equipment off (standby).
4	Alarm	Generates the alarm <i>Remote Connection Fault</i> .

7.6.2 LiBus messages to the EtherCAT interface (ECM state)

Number	Designation	Description
Alarms		
22	Connection Loss	The EtherCAT interface reports "sync manager watchdog timeout". Triggering of this alarm is defined via the operating mode of the CLM parameter, see Chapter 7.5.1 "Configuring the safe state" on page 31.
Warnings		
1	CAN Rx Overflow	An overflow into the CAN receive buffers resulted in the loss of one or more CAN messages.
33	Connection Loss	The EtherCAT interface reports "sync manager watchdog timeout". Triggering of this alarm is defined via the operating mode of the CLM parameter, see Chapter 7.5.1 "Configuring the safe state" on page 31.
35	Set Out of Range	The EtherCAT master sets a value outside of the valid value range. The warning remains active until a valid value is received.
Error		
9	LiBus Error	Indicates the failure of the LiBus, see below.

LiBus failure

The EtherCAT interface continuously checks whether the LiBus is active. The *R_KENNUNG*(Identifier) message is monitored by a timeout. If this message is not received within 2000 ms, this is interpreted as a LiBus failure:

- The "LiBus Error" is set and remains active until the constant temperature equipment is switched off.
- Communication with the constant temperature equipment is switched to the EtherCAT state "*Init*". EtherCAT error code 20h (= AL Status Code) indicates that the constant temperature equipment must be restarted ("slave needs cold start").

8 Maintenance

The interface module is maintenance-free.

Any dust and dirt deposits should be cleaned from the connections on the interface module on a regular basis, especially if the interfaces are not being used.



WARNING!
Live parts in contact with cleaning agent

Electric shock, material damage

- Disconnect the device from the mains supply before starting any cleaning work.
- Water and other fluids should not be allowed to enter the device.



NOTICE!
Repairs performed by unauthorized persons

Material damage

- Only specialized personnel are permitted to carry out repairs.

1. Use a damp cloth or brush to remove any dust and dirt deposits.
2. When using compressed air: Always set a low working pressure to prevent mechanical damage to the connections.



If you have any questions about technical modifications, please contact LAUDA Service, see ↗ Chapter 1.6 “Contact LAUDA” on page 7.

9 Faults

If a fault occurs, the interface distinguishes between different message types, e.g. alarms, errors and warnings. The procedure for rectifying a fault depends on the device. Follow the corresponding instructions in the operating manual accompanying the constant temperature equipment.



If you are unable to rectify a fault, please contact LAUDA Service, see [↗](#) Chapter 1.6 “Contact LAUDA” on page 7.

9.1 Alarm

The EtherCAT interface recognizes the following alarms:

Table 16: EtherCAT alarms

Code	Meaning
22	Loss of connection on the interface module

9.2 Error

The EtherCAT interface recognizes the following error messages:

Table 17: EtherCAT error messages

Code	Meaning
1901	Error in CPU
1902	Error in register
1903	RAM error
1904	ROM error
1905	Clock/PLL error
1906	24 V supply is too low
1907	24 V supply is too high
1908	Backup flash error burst

In the error bit field, the return value of the flash restore function is stored in bit position 65-80 (16 bit). The return values for parameter flash storage are defined in the common area. The binary combination of these bits must be regarded as a value according to the following list:

Table 18: Return value of the flash restore function

Number	Type	Meaning
1	Warning	The version stored in the flash is different to the current version.
2	Warning	The version on Page0 is different to the version on Page1 (only dual).
3	Warning	The flash does not contain any data.
4	Warning	Page0 has a CRC error.
5	Warning	Page1 has a CRC error.
6	Warning	PG0 has a CRC error.
7	Warning	PG1 has a CRC error.
8	Error	More data is being written than can fit on one page.
9	Error	Could not delete a page.
10	Error	Could not write a page.
11	Error	Flash pointer is not permitted (does not point to BACKUPVAR).
12	Error	Length in the FLASH is different to the length in the table.

9.3 Warning

The EtherCAT interface recognizes the following warnings:

Table 19: EtherCAT warnings

Code	Meaning
1901	CAN reception overflow
1902	Failure detection reset
1903	Connection interrupted
1904	Serial number missing
1905	Parameter out of value range
1908	Internal data exchange issue
1909	Unknown module connected
1910 – 1928	Software version of the specified component is too old

10 Decommissioning



WARNING!
Touching live parts

Electric shock

- Disconnect the device from the power supply before starting any installation work.
- Always observe safety measures against electrostatic discharge.

Decommission the interface module by removing it from the constant temperature equipment:

1. Observe the information in [↗](#) Chapter 5.1 “Installing the interface module” on page 14. Proceed in reverse order to remove.
2. Always attach the LiBus connecting cable to the inside of the module slot cover.
3. Fit the cover to the vacant module slot to protect the constant temperature equipment against the ingress of dirt.
4. Protect the interface module against static charging before placing it in storage. The storage location must meet the ambient conditions specified in the technical data.
5. If you intend to dispose of the module, please read the information in [↗](#) “Old device” on page 40 first.

11 Disposal

Packaging

The packaging normally consists of environmentally friendly materials that can be easily recycled when properly disposed of.

1. Dispose of packaging materials in accordance with the applicable disposal guidelines in your region.
2. Comply with the requirements of Directive 94/62/EC (packaging and packaging waste) if disposing of the product in a member state of the EU.

Old device



The device must be properly decommissioned and disposed of at the end of its life cycle.

1. Dispose of the device in accordance with the applicable disposal guidelines in your region.
2. Comply with Directive 2012/19/EU (WEEE Waste of Electrical and Electronic Equipment) if disposing of the product takes place in a member state of the EU.

12 Technical data

Feature	Unit	Value / version	
Interface module			
Catalog number	[-]	LRZ 922	LRZ 923
Size of module slot, W x H	[mm]	51 x 27	
External dimensions (excluding connectors), W x H x D	[mm]	56 x 40 x 80	
Weight	[kg]	0.1	
Operating voltage	[V DC]	24	
Maximum current consumption	[A]	0.1	
Number of inputs / outputs	[-]	1 / 1	1 / 1
Connection type	[-]	2x M8 sockets, 4-pin	2x RJ45 connection, 8-pin
Ambient conditions			
Air humidity	[%]	Maximum relative air humidity 80 % at 31 °C and up to 40 °C, 50 % with linear decrease.	
Ambient temperature range	[°C]	5 – 40	
Temperature range for storage	[°C]	5 – 50	

13 Index

A	
Alarm	37
C	
CANopen objects	29
Cleaning	36
Compatibility	6
Contact	7
Copyright	6
D	
Disposal	
Old device	40
Packaging	40
E	
Error	37
EtherCAT	11
Fault	37, 38
EtherCAT interface	
Abbreviations	19
Application protocols	21
Contact assignment of Ethernet connection	17
Contact assignment of M8 connection	17
Device	20
Distributed Clock	21
EEPROM	21
EtherCAT operating statuses	22
Field Bus Memory Management Units	21
Identifier	19
Local addresses	20
Menu structure	22
Ports	20
Sync Manager	20
EtherCAT module	
Purpose	11
F	
Fault	37
Fieldbus	11
I	
Improper use	5
Intended use	5
Interface functions	
Availability	27
Read commands	23
Write commands	26
Interface module	
Decommissioning	39
Installation	14
Maintenance	36
Module box	16
Unpacking	10
L	
LED status signals	12
M	
Module box	16
Module slot	14
P	
Personnel qualification (overview)	9
Process data	
Control	26
Status	23
S	
Safety information	
General	8
Interface module	9
Service	7
Software update	18
T	
Technical changes	6
U	
Update	18
W	
Warning	38



Warranty 6

Manufacturer:

LAUDA DR. R. WOBSE GMBH & CO. KG ° Laudaplatz 1 ° 97922 Lauda-Königshofen

Telephone: +49 (0)9343 503-0

E-mail: info@lauda.de ° Internet: <https://www.lauda.de>