

## Operating instructions

### PROLINE Kryomats

Low-temperature Thermostats  
with SmartCool System

**RP 3050 C, RP 3050 CW**  
**RP 4050 C, RP 4050 CW**  
**RP 3090 C, RP 3090 CW**  
**RP 4090 C, RP 4090 CW**

Valid from series: 07-0001 (see item 9.3.7)  
YAUE0007 / 01/09

from software version of Control system (Master) 2.09  
from software version of Protection system (Master) 2.02  
from software version of Operating system (Command) 2.06  
from software version of Cooling system 2.27  
from software version of Analogue interface 2.01  
from software version of RS232/485-Module 2.00  
from software version of contact I/O module 2.00

LAUDA DR. R. WOBSE  
R GMBH & CO. KG  
P.O. Box 1251  
97912 Lauda-Koenigshofen  
Germany

Phone: 0049 9343/ 503-0  
Fax: 0049 9343/ 503-222  
E-Mail [info@lauda.de](mailto:info@lauda.de)  
Internet <http://www.lauda.de>



## Prefixed safety notes



Before operating the equipment, please read carefully all the instructions and safety notes in Section 1.

If you have any questions, please phone us!

Follow the instructions on setting up, operation etc. This is the only way to avoid incorrect operation of the equipment and to ensure full warranty protection.

- The master head is supplied with power via the lower section of the unit. After switching off the head using the switch at the front of the head and/or using the switch at the back of the head, mains voltage (230 volts) is still present on the master head.

Switch off the unit by using the rotary switch on the front panel.

- Switch off the equipment and pull out the mains plug:
  - for servicing or repair,
  - moving the equipment!
- Transport the equipment with care!  
The unit may NEVER be overturned nor put upside down!
- Equipment and its internal parts can be damaged:
  - by dropping,
  - by shock.
- Technically qualified personnel must only operate the equipment!
- Never operate the equipment without the heat transfer liquid!
- Do not start up the equipment if ...
  - it is damaged or leaking,
  - cable (not only supply cable) is damaged.
- Drain the bath before moving the equipment!
- Do not carry out any technical changes on the device!
- Have the equipment serviced or repaired by properly qualified personnel only!

**The Operating Instructions include additional safety notes, which are identified by a triangle with an exclamation mark. Carefully read the instructions and follow them accurately! Disregarding the instructions may have serious consequences, such as damage to the equipment, damage to property or injury to personnel!**

We reserve the right to make technical alterations!

## Contents

Prefixed safety notes .....	3
<b>1 SAFETY INFORMATION.....</b>	<b>7</b>
1.1 GENERAL SAFETY INFORMATION.....	7
1.2 OTHER SAFETY INFORMATION.....	7
<b>2 BRIEF OPERATING INSTRUCTIONS .....</b>	<b>9</b>
2.1 MENU STRUCTURE: MASTER.....	10
2.2 MENU STRUCTURE: COMMAND.....	11
<b>3 CONTROLS AND FUNCTIONAL ELEMENTS .....</b>	<b>12</b>
<b>4 UNIT DESCRIPTION .....</b>	<b>17</b>
4.1 ENVIRONMENTAL CONDITIONS.....	17
4.2 TYPES OF UNIT .....	17
4.3 VARIOFLEX PUMP .....	17
4.4 MATERIALS.....	18
4.5 TEMPERATURE DISPLAY, CONTROL AND SAFETY CIRCUIT .....	18
4.6 PROGRAMMER AND RAMP FUNCTION .....	19
4.7 INTERFACES .....	19
4.8 INTERFACE MODULES (ACCESSORIES).....	19
4.9 REFRIGERATING UNIT.....	20
4.10 AVOIDANCE OF DEWING.....	20
4.11 HEATER RATING AND POWER CONSUMPTION FROM THE MAINS.....	20
<b>5 UNPACKING .....</b>	<b>21</b>
5.1 AFTER UNPACKING.....	21
5.2 STANDARD ACCESSORIES .....	21
5.3 PACKING AND UNPACKING WITH ORIGINAL VERPACKUNGSMATERIAL .....	21
5.3.1 <i>Background</i> .....	21
5.3.2 <i>Voraussetzungen</i> .....	21
5.3.3 <i>Auspacken des Gerätes</i> .....	22
5.3.3.1 <i>Umverpackung</i> .....	22
5.3.3.2 <i>Gerät von der Palette heben</i> .....	24
5.3.3.3 <i>Vor der Inbetriebnahme</i> .....	25
<b>6 PREPARATION.....</b>	<b>26</b>
6.1 ASSEMBLY AND SITING .....	26
6.2 FILLING AND DRAINING.....	27
6.3 HEAT TRANSFER LIQUIDS AND HOSE CONNECTIONS .....	28
6.4 CONNECTING EXTERNAL LOADS.....	30
<b>7 STARTING UP.....</b>	<b>31</b>
7.1 MAINS CONNECTION .....	31
7.2 SWITCHING ON .....	31
7.3 SWITCHING OFF / STANDBY .....	33
7.4 KEY FUNCTIONS.....	34
7.4.1 <i>General key functions and pilot lamps</i> .....	34
7.4.2 <i>Changing window information (Command Console)</i> .....	38
7.4.3 <i>Locking the keyboard</i> .....	39
7.5 IMPORTANT SETTINGS .....	41
7.5.1 <i>Temperature setpoint setting</i> .....	41
7.5.2 <i>Displaying the actual external temperature</i> .....	43
7.5.3 <i>Setting pump power or standby</i> .....	44
7.5.4 <i>Activate external pump</i> .....	46

7.5.5	Activating external control .....	46
7.5.6	Current consumption from the mains.....	48
7.5.7	Setting the date and time (Command).....	49
7.5.8	Display resolution setting (Command).....	50
7.6	SPECIAL SETTINGS .....	51
7.6.1	Defining the type of start mode.....	51
7.6.2	Defining temperature limits.....	52
7.6.3	Setpoint offset operating mode.....	53
7.6.4	Restoring works settings .....	54
7.6.5	Setting the volume of the acoustic signals.....	55
7.6.6	Entering the offset of the internal temperature probe.....	55
7.6.7	Restoring the works setting of the internal temperature-probe offset.....	56
7.6.8	Entering the offset of the external temperature probe .....	57
7.6.9	Restoring the works setting of the external temperature-probe offset .....	57
7.7	GRAPHICAL DISPLAY OF TEMPERATURE MEASUREMENTS (COMMAND).....	58
7.8	PROGRAMMER (PGM ONLY COMMAND) .....	60
7.8.1	Program example.....	60
7.8.2	Selecting and starting the program (Start, Hold, Stop) .....	62
7.8.3	Interrupting, continuing or terminating the program (Hold, Continue, Stop).....	63
7.8.4	Creating or modifying a program (Edit).....	64
7.8.5	Defining the number of program loops (Loops) .....	68
7.8.6	Viewing the program sequence as a graph (Graph).....	68
7.8.7	Obtaining information on a program (Info).....	69
7.9	RAMP FUNCTION.....	70
7.10	TIMER FUNCTION (COMMAND).....	71
7.11	CONTROL PARAMETERS .....	72
7.11.1	Internal control variable (integral measurement probe).....	73
7.11.1.1	Proven settings for control parameters and pump (integral measurement probe).....	73
7.11.2	External control variable (External measurement probe).....	73
7.11.2.1	Steps for setting the control parameters for external control .....	74
7.12	ALARMS, WARNINGS AND ERRORS .....	75
7.12.1	Overtemperature protection and checking.....	75
7.12.2	Low-level alarm and low-level checking.....	77
7.12.3	High-level settings .....	77
7.12.4	High-level warning or alarm .....	78
7.12.5	Pump-motor supervision: Overload or blockage.....	79
7.12.6	Pump-motor supervision: Dry running.....	79
7.12.7	Compressor Overtemp.....	80
7.12.8	Three-phase current.....	80
7.12.9	Fault list „Alarms and Warnings“.....	81
7.13	RS 232/ RS 485 INTERFACE.....	84
7.13.1	Connecting cables and interface test RS 232.....	84
7.13.2	Protocol RS 232 .....	84
7.13.3	Connecting cable RS 485.....	85
7.13.4	Protocol RS 485 .....	85
7.13.5	Write commands (Data commands to the thermostat).....	86
7.13.6	Read commands (Data requested from the thermostat).....	87
7.13.7	Error messages .....	89
7.13.8	Driver software for LABVIEW®.....	89
<b>8</b>	<b>INTERFACE MODULES.....</b>	<b>90</b>
8.1	INSTALLING OF MODULES .....	90
8.2	MENU STRUCTURE FOR ALL MODULES (ONLY COMMAND) .....	91
8.3	SERIAL INTERFACES RS232/ 485 .....	92
8.4	ANALOGUE MODULE.....	92
8.5	CONTACT MODULE .....	93
8.5.1	Contact module LRZ 915 with three inputs and three outputs.....	93
8.5.2	Namur-Contact module LRZ 914 with only one input and one output.....	94

<b>9</b>	<b>MAINTENANCE</b> .....	<b>95</b>
9.1	DEVICE STATUS.....	95
9.1.1	Interrogating the device type.....	95
9.1.2	Software version.....	95
9.1.3	Serial numbers.....	95
9.1.4	Device data.....	95
9.1.5	Fault memory (Command).....	96
9.2	CLEANING .....	96
9.2.1	Cleaning the surface of the device.....	96
9.2.2	Draining the water-cooled condenser.....	97
9.3	SERVICING, CLEANING, REPAIR AND DISPOSAL INFORMATION.....	97
9.3.1	Servicing.....	97
9.3.2	Service intervals according to VDI 3033.....	98
9.3.3	Testing the heat transfer liquid.....	98
9.3.4	Cleaning the condenser .....	99
9.3.4.1	Air-cooled condenser.....	99
9.3.4.2	Water-cooled condenser .....	99
9.3.4.2.1	Cleaning the dirt trap .....	99
9.3.4.2.2	Decalcifying the water cooling circuit.....	100
9.3.5	Repair information .....	100
9.3.6	Disposal information.....	101
9.3.6.1	Disposal of the refrigerant .....	101
9.3.6.2	Disposal of the packaging.....	101
9.3.7	Remedying faults .....	102
9.4	HELP DESK AND ORDERING REPLACEMENT PARTS.....	104
<b>10</b>	<b>ACCESSORIES</b> .....	<b>105</b>
<b>11</b>	<b>TECHNICAL DATA AND DIAGRAMS</b> .....	<b>106</b>
<b>12</b>	<b>INDEX</b> .....	<b>112</b>
	<b>CONFIRMATION</b> .....	<b>115</b>

### Explanation of signs:



**Danger:** This sign is used where there may be injury to personnel if a recommendation is not followed accurately or is disregarded.



**Note:** Here special attention is drawn to some aspect. It may include reference to danger.



**Reference** It refers to other information in different sections.

## 1 Safety information

### 1.1 General safety information

A heating and cooling thermostat heats or cools and circulates heat transfer liquids according to specified parameters. This involves hazards due to high or low temperatures, fire and general hazards due to the application of electrical energy.

The user is largely protected by the application of relevant standards.

Further hazard sources may arise due to the type of tempering medium, e.g. by exceeding or undercutting certain temperature thresholds or by the breakage of the container and reaction with the heat transfer liquid.

It is not possible to consider all eventualities. They remain largely subject to the judgment and responsibility of the operator.

The equipment must only be used as prescribed and as described in these operating instructions. This includes operation by instructed specialist personnel.

The equipment is not rated for use under medical conditions according to DIN EN 60601-1 or IEC 601-1.

#### **For Europe:**

The equipment fulfills the following classes of the EMC (electromagnetic compatibility) standard EN 61326-1 VDE 0843-20-1:2006-10:

Class A: Operation only on networks without connected domestic areas.

Class B: Equipment for operation on networks with connected domestic areas.

Class B\*: Equipment fulfills Class B when a house connection > 100 A is involved. With unfavorable network conditions disturbing voltage variations may otherwise occur.

#### **Only for the USA:**

Instructions for Class A digital devices

“This equipment has been tested and found to comply with the limits for Class A digital device, pursuant to Part 15 of the FCC (Federal Communication Commission) Rules. These limits are designed to provide reasonable protection against harmful interference when the equipment is operated in a commercial environment. This equipment generates, uses, and can radiate radio frequency energy and, if not installed and used in accordance with the instruction manual, may cause harmful interference to radio communications. Operation of this equipment in a residential area is likely to cause harmful interference in which case the user will be required to correct the interference at his own expense.”

“This device complies with Part 15 of the FCC (Federal Communication Commission) Rules. Operation is subject to the following two conditions: (1) This device may not cause harmful interference, and (2) this device must accept any interference received, including interference that may cause undesired operation.”

#### **Only for Canada:**

“This Class A digital apparatus complies with Canadian ICES-003” (ICES = Interference Causing Equipment Standards).

« Cet appareil numérique de la Classe A est conforme à la norme NMB-003 du Canada ».

### 1.2 Other safety information

- Only connect equipment to PE grounded mains sockets.
- At higher operating temperatures, parts of the bath cover can reach surface temperatures exceeding 70 °C. Be careful when touching it! → Danger of burning!
- Use suitable hoses ⇒ 6.3.
- Secure hose against slippage with the aid of hose clips. Avoid kinks in the hoses.
- Check hoses from time to time for any possible material fatigue.
- Thermal medium hoses and other hot parts must not come into contact with the mains cable.

- With the use of thermostats as circulating thermostats hot or cold liquid can be emitted when the hose breaks, presenting a hazard to persons and material.
- If no external load is connected, the pump outflow must be closed (use screw plugs) and the bypass valve must be set to "internal" ⇒ 4.3.
- Take into account the thermal expansion of the heat transfer oils with increasing bath temperature.
- Depending on the heat transfer liquid used and the type of operation, toxic vapors can arise. Ensure suitable extraction.
- By changing the heat transfer liquid from aqueous heat transfer liquid to a thermal transfer liquid for temperatures above 100°C, carefully remove all water residues, including from the hoses and loads. **When doing this, also open the blanking caps of the pump outputs and inputs and blow compressed air through all the pump outputs and inputs.** → Danger of scald due to delay in boiling!
- Withdraw the mains plug before cleaning, maintenance or moving the thermostat.
- Specialist personnel must only carry out repairs in the control section.
- The following action may start the thermostat unintentionally from the standby mode: Previously activated timer mode (⇒ 7.10), "Start" command via interfaces (⇒ 8).
- Figures of temperature constancy and display accuracy apply under normal conditions according to DIN 12876. Electromagnetic high frequency fields may in special cases lead to unfavorable values. Safety is not impaired.

Only water-cooled devices:

- The return hose of the water cooling must be securely fixed on the outlet port in order to prevent the hose sliding off uncontrollably, also during pressure surges.
- The return hose of the water cooling must be fixed on the outlet port that hot cooling water cannot splash out.
- It is essential to prevent kinking or squashing of the return hose for the water cooling. Excessive pressure can cause the cooling water hoses to tear and hot water to escape.
- To prevent damages by a leakage of the cooling water system its recommended to use a leak-water detector with shut-off valve (Aqua Stop).

## 2 Brief operating instructions



These brief instructions shall give you the possibility to operate the unit quickly. For safe operation of the unit, it is necessary to read carefully all the instructions and safety notes!

1. Assemble unit and add items as appropriate (⇒ 6.1).  
The unit may NEVER be overturned nor put upside down!  
Take care of the hose tubing connections (⇒ 6.3 and 6.4).
2. Fill the unit with corresponding heat transfer liquid (⇒ 6.3). The units are designed for operation with non-flammable and flammable liquids to DIN EN 61010-2-010. → Take care of the level of the heat transfer liquid! (⇒ 6.2).
3. Compare the information on the rating label with the supply details.
4. Connect the unit only to a socket with a protective earth (PE) connection.



5. Check whether the switch  at the back of the master control element is in the "ON = -" position.



6. Check whether the switch  at the front of the master control element is in the "ON = I" position.

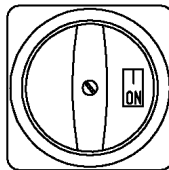

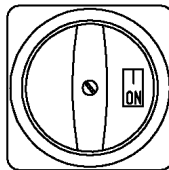
7. Set the rotary switch  on the front panel to "ON = I". The unit starts operating.



8. With  set the overtemperature cut-off point to a value clearly above room temperature (⇒ 7.12.1).
9. Now you see the current bath temperature in the display, for example:

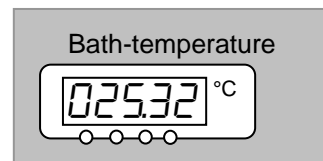

If instead, a warning or error message is displayed, then refer to Section 7.12.

## 2.1 Menu structure: Master

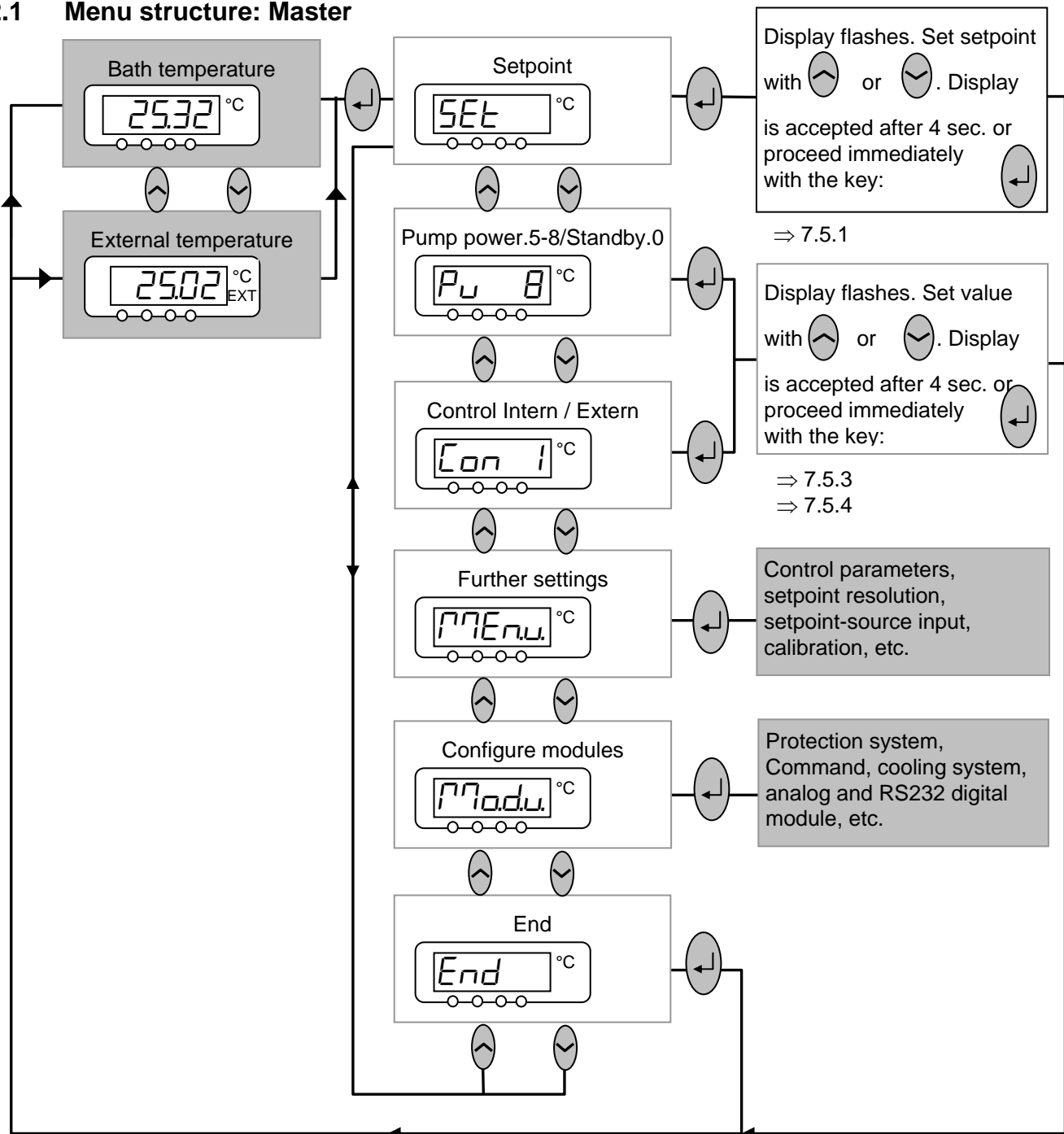

These settings and configurations can be entered more easily and in a more clear manner via the Command control element. Therefore, for the Master control element they are not explained in more detail in this operating manual.

## 2.2 Menu structure: Command

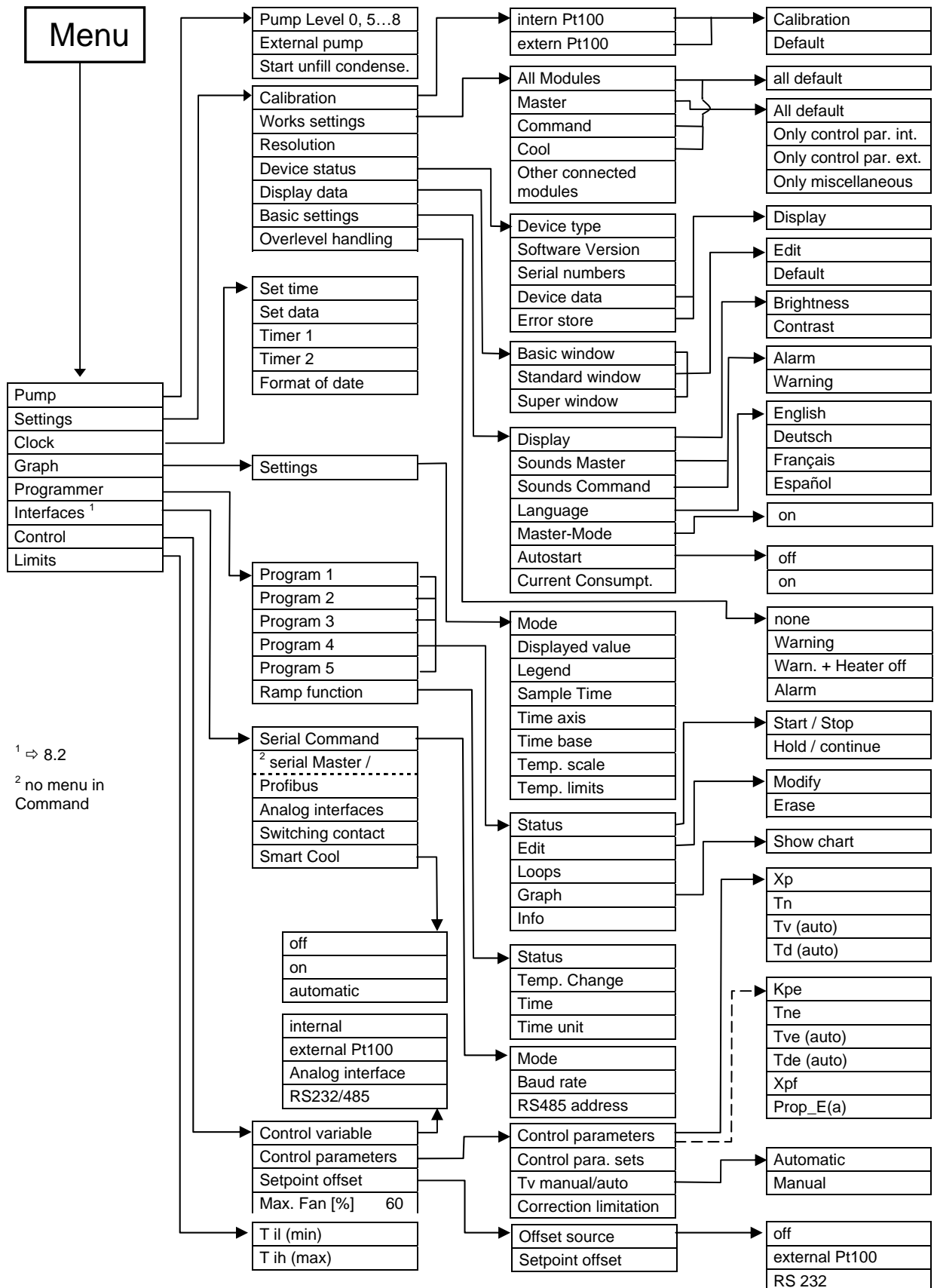

<sup>1</sup> ⇒ 8.2

<sup>2</sup> no menu in Command

### 3 Controls and functional elements



- |  |   |
|--|---|
| 1 Mobile Command control element (see page 15)   | 5 Bath cover  |
| 2 Master control element   | 6 Rotary switch for power supply                              |
| 3 Pump connection on the side:<br>Pump outflow or pressure output<br>Suction nozzle (return to bath) | 7 Front cover (closed)  |
| 4 Bypass valve (see illustration on this page).  | 8 Grille (on both sides)                                      |
|  | 9 Four steering transport rollers, two off them with stoppers |

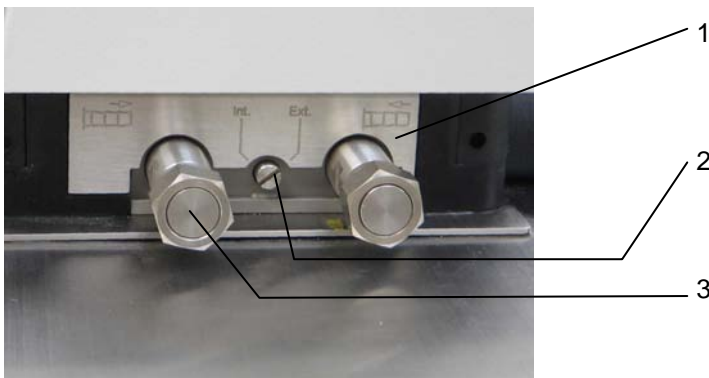

Pump connection on the side:

- |  |  |
|--|--|
| 1 Suction nozzle (return to bath)<br>Pump outflow or pressure output<br>(closed off with screw plug)<br>refer to housing for label | 2 Bypass valve<br>(in "external" position)   |
|  | 3 Pump outflow, pressure output<br>Suction nozzle (return to bath)<br>(closed off with screw plug)<br>refer to housing for label |

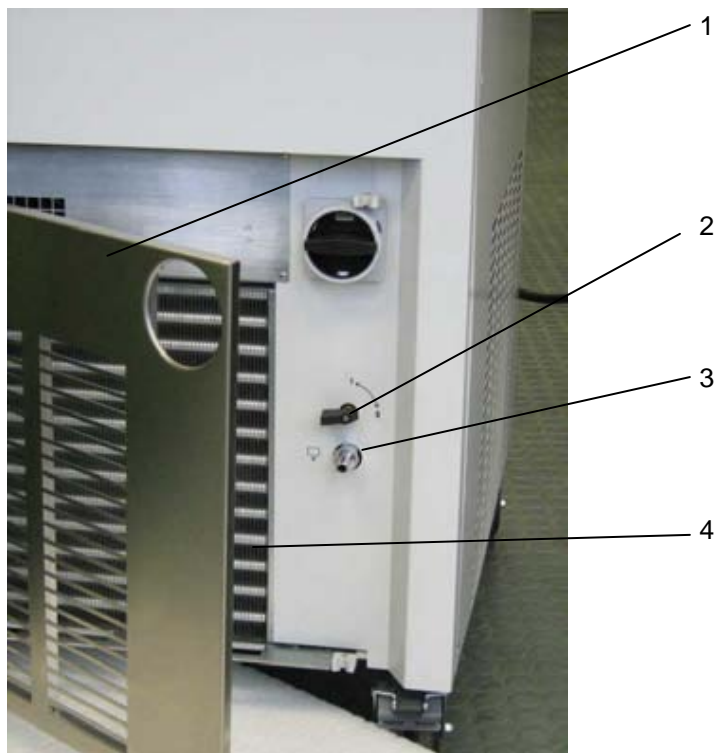

1 Front cover (open)

2 Bath drain tap

3 Bath drain nozzle

4 Condenser

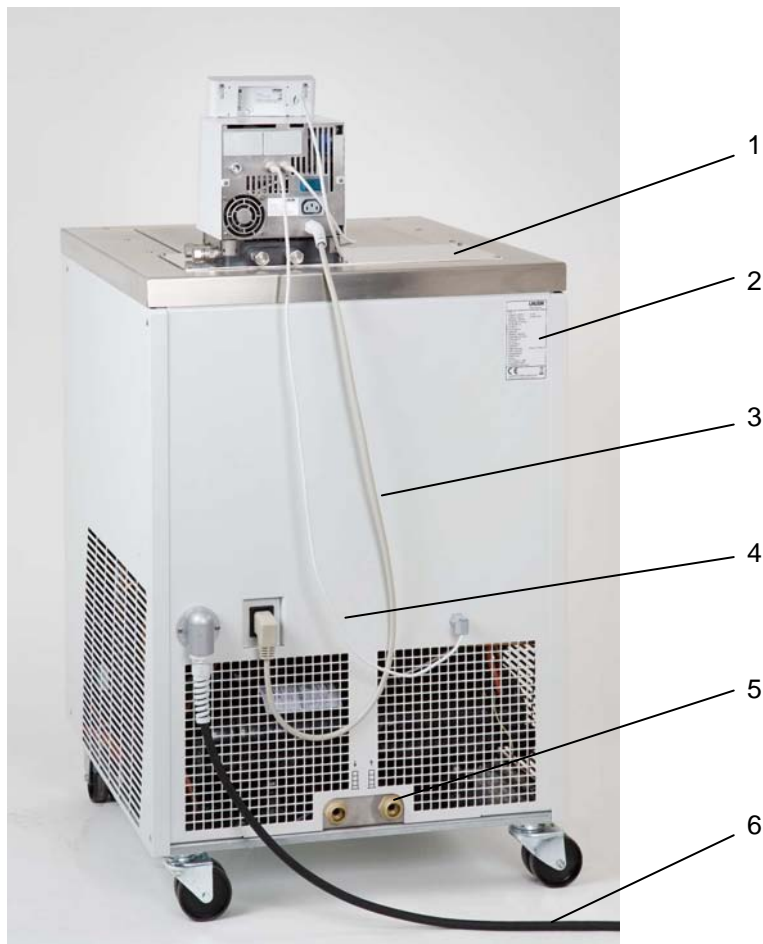

- |   |                                   |   |  |
|---|-----------------------------------|---|--|
| 1 | Bath bridge heating               | 4 | Connection cable LiBus                                     |
| 2 | Rating label                      | 5 | Cooling water connections (at water-cooled devices W only) |
| 3 | Connection cable for control head | 6 | Mains cable  |

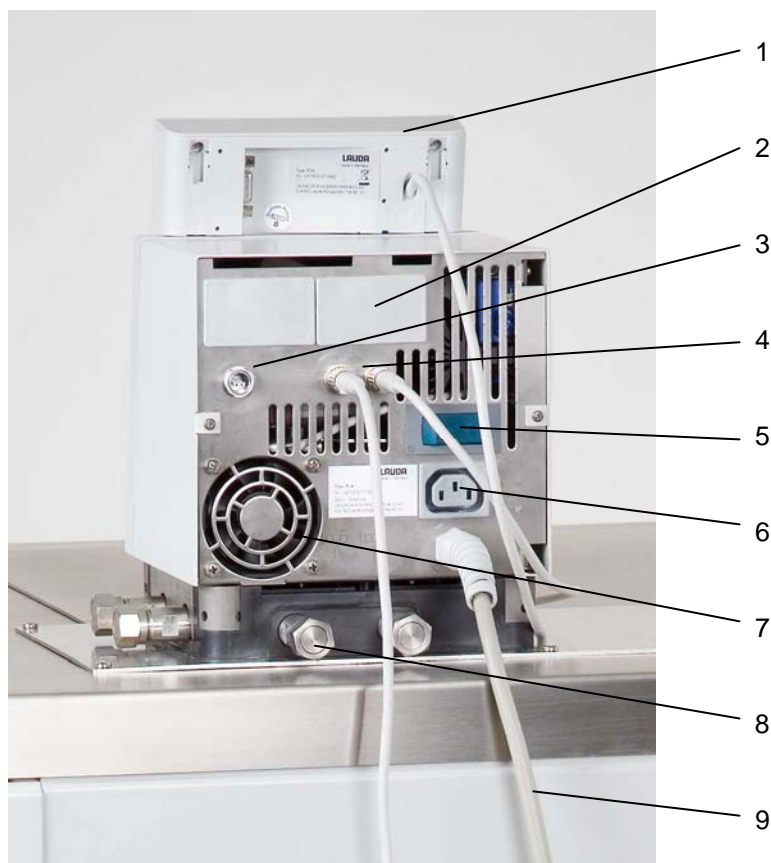

- |   |  |   |   |
|---|--|---|---|
| 1 | Mobile Command Console (see next page)   | 6 | Connection socket 51H   |
| 2 | Covers for the two module slots  | 7 | Air intake for electronic head  |
| 3 | Connection socket 10S<br>for the external Pt100 temperature probe  | 8 | Pump connection rear and on the side:<br>Suction nozzle (return to bath) & pump outflow<br>or pressure output<br>refer to housing for label |
| 4 | Connection socket 70S (LAUDA internal bus<br>(LiBus)) for bus suitable for unit and to which the<br>refrigerating lower section and Command Console<br>are connected | 9 | Mains connecting lead   |
| 5 | Mains switch   |   |   |

### Control element: Master

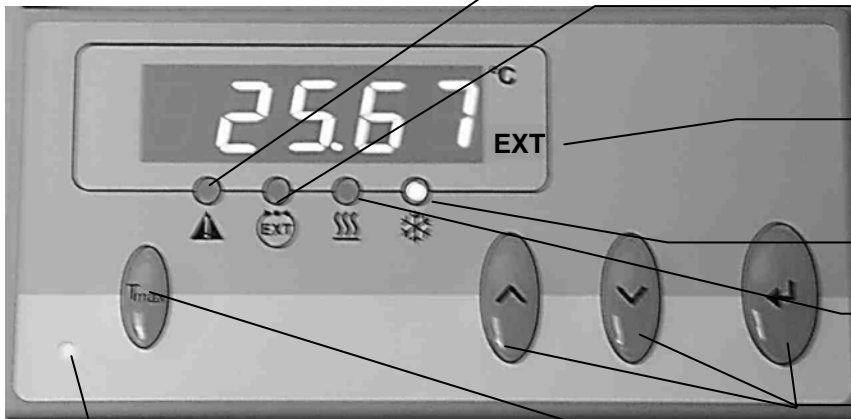

Error signal (red LED is blinking)

Bath controlled by external temperature source (green LED is lit)

The temperature of an external source is displayed (EXT is lit green)

Cooler active (blue LED is lit)

Heater active (yellow LED is lit)

Select and Enter keys

Overtemperature set point to check or set  $T_{max}$

Mains On (green LED is lit)

Graphical display, here in the standard window displaying the values:

- Actual temperature  $T_{int}$  of internal bath temperature probe
- Setpoint temperature  $T_{set}$
- Actual temperature  $T_{ext}$  of the external temperature probe
- Bath level
- Pump level

### Control element: Command

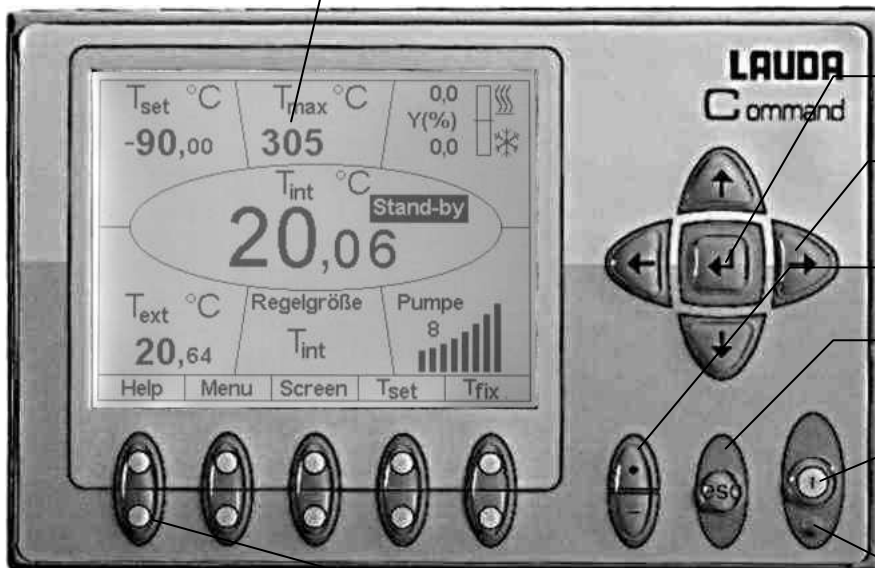

Enter key

Cursor key

Decimal point or "-" symbol

Escape key to quit a window without any changes

Standby key, brings the thermostat into the idle mode. Heater,

Yellow Stand-By LED

Five soft-key duo-keys – their associated functions are shown in the display.

RS 232-socket (hidden on the back of Command)

## 4 Unit description

### 4.1 Environmental conditions

The operation of the thermostats is only allowed under the following conditions as specified in DIN EN 61010-2-010:2003 and DIN EN 61010-1:2001:

- Indoor use only.
- Altitude up to 2000 m above sea level.
- Foundation must be dense, even, non-slippery and non-flammable.
- Keep clear distance (⇒ 6.1 Assembly and siting).
- Ambient temperatures range (⇒ 11 Technical data).  
Use only within this range for an undisturbed operation.
- Mains supply voltage fluctuations (⇒ 11 Technical data).
- Relative humidity (⇒ 11 Technical data).
- Transient over voltage according to Installation Categories (Over voltage Categories) II.
- Pollution degree: 2.

### 4.2 Types of unit

The type designation of the Proline Kryomats comprises the prefix R (to designate the refrigeration machine), a P for Proline, the bath volume in liters and the lowest bath temperature (guide figure without arithmetic sign).

The designation is supplemented with a "C" which indicates the presence of the Command control element.

For units with water-cooling, the type designation is supplemented with a "W".

Examples: RP 4090 CW is a low-temperature thermostat with 40-liter bath and -90 °C lowest temperature. The unit has a Command control element and is water-cooled.

### 4.3 VarioFlex pump

All units are fitted with a VarioFlex pump with a 4-stage variable drive (pump level 5 to 8). The pump power can therefore be optimally matched to the relevant task. In order to achieve optimum temperature homogeneity in the heat transfer liquid in the bath, it is recommended to select the pump level in dependence of the viscosity of the heat transfer liquid; therefore at higher viscosity to increase the pump level.

Be cautious at higher bath levels to avoid liquid to slop over the bath edge.

The user cannot set the pump levels 1 to 4, because there is no sufficient temperature homogeneity in the bath vessel. With pump level 0 the unit goes into the standby mode. It should be noted that the heat input of the pump into the bath increases with increasing pump level.

With the VarioFlex pump, open containers can be operated at a constant level when a level controller (accessory LCZ 0660) is used.

At the right-hand side and at the back of the unit outflow and inflow nozzles of the pump are fitted for external loads. This means that up to two external loads can be directly connected without a distributor. Pump connections, which are not required, must be closed off with the supplied caps and union nuts.

A bypass valve can subdivide the total volume flow variably between the bath (internally) and the connected load (externally). Attention: the external application must not block the volume flow. If no load is connected to the pump connector, the bypass valve must be set to the "internal" position for the best bath circulation. All pump connections must be closed off with the supplied caps and union nuts.

The pump connections on the unit are fitted with M16 x 1 thread.

The VarioFlex pump operates short-term up to viscosities of 150 mm<sup>2</sup>/s. In the closed-loop control mode 50 mm<sup>2</sup>/s should not be exceeded. The temperature control is the best with 30 mm<sup>2</sup>/s and lower viscosity.

For operation as a circulating thermostat with an external load, the highest possible power level is practicable to maintain the temperature difference low, among other things also with higher temperatures in conjunction with oils as heat transfer liquid.

**Pump characteristics** (⇒ 11).

#### 4.4 Materials

All parts being exposed to the heat transfer liquid are made of high quality material appropriate to the operating temperature. Non-rusting stainless steel and high quality temperature-resistant, primarily solvent-resistant plastics are used.

#### 4.5 Temperature display, control and safety circuit

The Master control element is equipped with a 5-character green LED display, which is used for the display of the measurements and settings, as well as the operating status. The entry of setpoints and other settings occurs under menu guidance via four keys.

The more comfortable and removable Command control element includes a backlit graphical display. The entry of the setpoint and other settings occurs under menu guidance via situation-dependent cursor keys and soft keys.

A Pt100 temperature probe acquires the current temperature in the bath. A high-resolution A/D converter processes the measurement. Further measurement conditioning occurs using a special control algorithm for controlling the heater actuator, which has a low reactive effect on the mains, and the SmartCool refrigeration equipment together with further transducers.

An external Pt100 temperature probe can be connected via a socket (10S) for the acquisition of an external temperature. This value can be displayed and, if required, used as the controlled variable with external control (Master) switched on. In this way, the system controls the external measurement and not the internal bath temperature (⇒ 7.5.4).

The safety system conforms to DIN EN 61010-2-010. The SelfCheck Assistant monitors about 50 unit parameters. A dual-channel system is used in which two microcontrollers monitor one another. Along with the bath temperature measurement and control probes, there are also two safety temperature probes (Pt100) for the safety circuit for the overtemperature cut-off and for monitoring the bath temperature probe.

The overtemperature cut-off point is displayed on pressing the key  on the Master.

Changing the overtemperature cut-off point: (⇒ 7.2 Switching on) on page 31.

The bath level is acquired by the SelfCheck Assistant in 8 stages. If the minimum level is undercut, the pump, heater and the SmartCool System refrigerating machine are switched off. The reaction of the thermostat in case of overfill can be set to simply display a warning, to display a warning and switch off the heater or to switch off the unit completely with pump, heater and SmartCool System refrigerating machine.

When the level is too low, with overtemperature, or with other alarms the SelfCheck Assistant switches the heater off on all poles. The pump and the refrigerating machine are also switched off. This switch-off under fault conditions is retained, i.e. after the fault is rectified, the fault must be reset

(released) on the Master operating panel with the  key.

Other unit functions are described in the appropriate sections and in Section 7. (Starting up).

#### 4.6 Programmer and ramp function

##### Master control element:

No programmer provided.

##### Command control element:

The units are equipped with a programmer function, which enables five temperature/ time programs to be saved. Each program consists of a number of temperature/ time segments. These also include details of how often the program is to be executed. Up to 150 segments can be distributed amongst the five programs.

With the ramp function, a rate of change can be directly entered in K/ unit time ( $\Rightarrow$  7.8).

#### 4.7 Interfaces

The device is equipped in series with the following sockets:

- One socket (10S) for the connection of an external Pt100 temperature probe.
- Two sockets (70S) for the connection of components via the LAUDA equipment bus (cooling section, Command control element, external solenoid valve, etc.).
- An RS232/485 interface (65S) at the back of the Command control element.

#### 4.8 Interface modules (accessories)

The Master control element can be supplemented with further interface modules, which are simply inserted into two module slots ( $\Rightarrow$  3) at the back of the control head.

The following modules are currently available:

1. **RS232 / 485 Interface Module** (Order No. LRZ 913) with 9-pole SUB-D socket. Electrically isolated through optocouplers. Command set largely compatible with the Ecoline, Integral XT and Integral T Series. The RS2323 interface can be directly connected to the PC with a cable wired 1:1 straight through (Order No. EKS 037). Further details can be found in section 8.3.
2. **Analog Module** (Order No. LRZ 912) with two inputs and two outputs on 6-pole DIN socket. The inputs and outputs can be set independently as 4...20 mA, 0...20 mA or 0...10 V interface. Further details can be found in section 8.4.
3. **Contact Module** (Order No. LRZ 915) on 15-pole SUB-D socket. With three relay contact outputs (changeover, max. 30V/ 0.2A) and three binary inputs for control via external voltage-free contacts. Plug 15-pole (Order No. EQM 030) and plug case (Order No. EQG 017). Further details can be found in section 8.5.
4. **Contact Module** (Order No. LRZ 914) with connector to NAMUR NE28. Functionality as LRZ 915, but only one output and only one input on each of two DIN sockets. Coupling socket 3-pole (Order No. EQD 047) and coupling plug 3-pole (Order No. EQS 048).

Further details can be found in section 8.5.

**5. Profibus Modules** (Order No. LRZ 917).

Further details can be found in the operating instructions (Order No. YAAE0020) of the **Profibus Modules**.

## 4.9 Refrigerating unit

The refrigerating machine mainly consists of one or two fully hermetically sealed compressors. The heat from the condensation process and the motor is dissipated via a lamellar condenser. Here, fresh air is drawn in at the front of the unit, heated in the unit and output at the back and the side. To ensure proper air circulation the ventilation slots must not be restricted respectively covered (⇒ 6.1).

The Proline Kryomats are equipped with the SmartCool technology, which makes optimum use of the compressor and only then cools when refrigerating capacity is demanded by the controller. To achieve this, a number of sensors in the cooling circuit monitor the operating conditions.

The compressors are equipped with overtemperature cutouts, which respond to the compressor temperature and the compressor current consumption. In addition, the refrigeration system is backed up by a pressure control device against over pressure. The cooling unit is normally switched in automatically, but can be switched manually via the operating menu with Command control element (⇒ 2.2) and with Master control element (⇒ 2.1).

When the fault circuit trips, the refrigerating unit is also switched off.

**Cooling curves** (⇒ 11).

## 4.10 Avoidance of dewing

In order to avoid dewing on the edge of the bath when using the low temperatures of the thermostats, these devices are equipped with a bath bridge heating and a bath edge heating.

## 4.11 Heater rating and power consumption from the mains

The Proline Kryomats has an extraordinarily high heater rating of 3.5 kW maximum. While the compressors are running the power consumption and therefore the heater power is reduced.

## 5 Unpacking

### 5.1 After unpacking

After unpacking, firstly check the device and accessories for any damage in transit. If, contrary to expectations, there is visible damage to the unit, the shippers or the postal service must be immediately informed, so that an investigation can be made. Please also inform the LAUDA Service Constant Temperature Equipment (Contact ⇒ 9.3.7).

### 5.2 Standard Accessories

Article number	Quantity	Article	
YAUE0007	1	Operating instructions (this document)	for all Kryomats
HDQ 120	1	Bath cover with grip	for RP 4050 C, RP 4050 CW, RP 4090 C and RP 4090 CW
HDQ 121	1	Bath cover with grip	for RP 3050 C, RP 3050 CW, RP 3090 C and RP 3090 CW
HKM 032	4	Union nuts for olives (M16 x 1)	already mounted, for all Kryomats
HKN 065	4	Screw plugs (for M16 x 1)	already mounted, for all Kryomats
EOA 001	2	Threaded house coupling Nipple ½"; Nut G ¾"	for water-cooled devices only
EZB 260	1	Warning label "Hot surface" 	for all Kryomats

### 5.3 Packing and Unpacking with original Verpackungsmaterial

#### 5.3.1 Background

Für Endkunden von Proline Kryomaten um eine ordnungsgemäße Verpackung, z. B. für den Rücktransport zum Hersteller oder zum Weitertransport, zu gewährleisten.



- Um das Gerät später sorgsam und sicher wieder verpacken zu können, ist es notwendig die Originalverpackung aufzubewahren.

#### 5.3.2 Voraussetzungen

Einen Kran mit zwei gleichlangen, gepolsterten Transportgurten oder einen Gabelstapler mit breitenverstellbarer Gabel.

## 5.3.3 Auspacken des Gerätes

### 5.3.3.1 Umverpackung



Öffnen Sie oben den Karton.

Palette

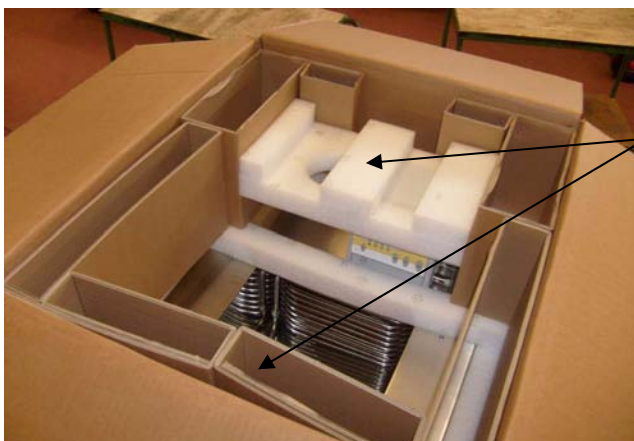

Entnehmen Sie das Füllmaterial und die Zubehörteile.



Entfernen Sie die Nägel an den 4 Ecken, welche den Karton auf der Palette fixieren.

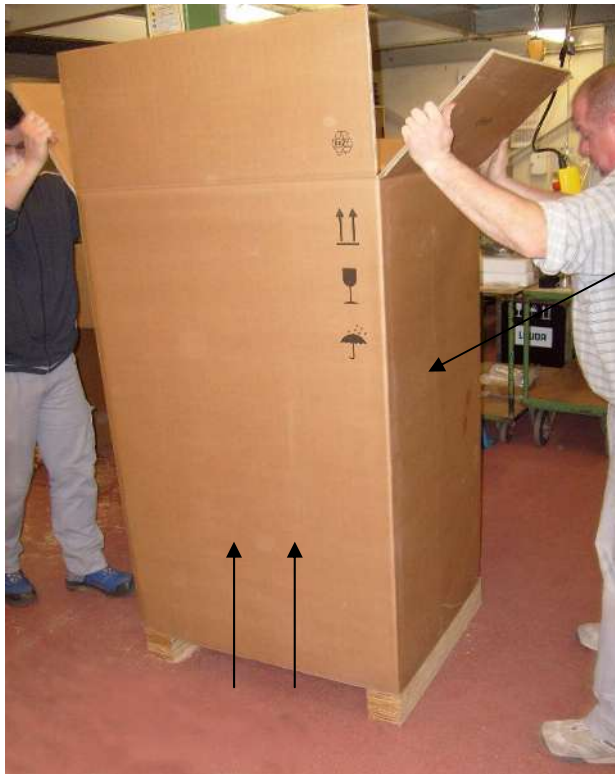

Nehmen Sie den Karton senkrecht nach oben über das Gerät ab.

### 5.3.3.2 Gerät von der Palette heben



Legen Sie die Gurtschlaufen zwischen Palette und den Rädern um das Gerät und führen Sie die Gurtschlaufen über der Gerätemitte zusammen. Heben Sie das Gerät anschließend von der Palette.

**Achtung:**  
Der Gurt darf nicht gegen den Aufbau des Gerätes drücken!



– Watch for center of gravity!

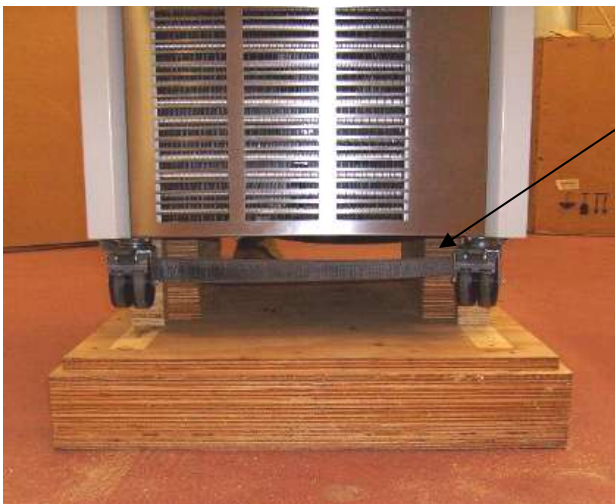

Vorderansicht der Gurtverlegung

Richten Sie ggf. die Räder gerade aus.



Seitenansicht der Gurtverlegung

### 5.3.3.3 Vor der Inbetriebnahme

- Schutzfolie abnehmen
- Für die Aufstellung und die Inbetriebnahme ist die Bedienungsanleitung zu beachten!

## 6 Preparation

### 6.1 Assembly and siting



- Site the unit on a flat surface
- The unit must not be put into operation if its temperature during storage or transport has dropped below the dew point. Wait for about one hour.
- The unit may NEVER be overturned nor put upside down!
- Do not cover the ventilation openings at the back of the control head and on all sides of the lower section of the unit.
- Leave at least 40 cm of free space on all sides.
- For operation as bath thermostat, set the bypass valve to internal (operation without external loads) (⇒ 3).
- Plug the mains-cable from the Master control element to the refrigerator unit into the socket 52H on the back of the Kryomat.
- Plug the LiBus connector of the Command control element into the 70S socket and secure it.
- Plug the LiBus cable from the refrigerator unit also into the socket 70S on the back of the Master control element and secure it.

#### Operation with external loads

(Circulating thermostat) continue at ⇒ 6.4.



- Check whether the pump connectors at the side and back are fitted with sealing caps (⇒ 3) or that hoses are fitted for external loads.



- Using bath temperatures over 70 °C the supplied self-adhesive label should be applied on the bath at an easily visible point.
- Do not carry out technical changes on the device!  
The edge of the bath must not be drilled!



- It is essential to keep within the permissible ambient temperature range (⇒ 11).
- An increased ambient temperature or increased cooling water temperature reduces the cooling capacity.

**6.2 Filling and draining**



**Filling**



- Close the drain cock.
- Carefully remove all residues of the previous heat transfer liquid (blow dry and remove screw plugs!).
- Maximum filling level is up to 10 mm below the top edge of the bath. Overfilling leads to the display of the warning **WARN 103** (⇒7.12.4). Changes in volume of the heat transfer liquid during temperature changes should be taken into account.
- Best operation is with a level 30-80 mm below the top edge of the bath.
- The cooling pipe of the evaporator should be covered.
- Low-level cut-off occurs at about 95 mm below the top edge of the bath.



- The units are designed for use with non-flammable and flammable liquids to DIN EN 61010-2-010. Flammable liquids must not be used higher than 25 °C below its fire point (⇒ 6.3).
- When using heat transfer oils note that they expand on heating (approx. 10%/ 100 K). With enclosed external loads, the overall expansion takes place in the bath of the Proline Kryomat.
- Ensure that with the connection of an external load, the liquid level does not drop impermissibly due to filling the load → top up with liquid if necessary.
- Set the upper and lower temperature limits (⇒ 7.6.2) in accordance with the limits of the heat transfer liquid in use.

**Draining**



Drain cock

- Switch off the thermostat on the mains switch (rotary switch) withdraw the mains plug.
- The drain cock is located behind the front panel.
- Unscrew the olive with union nut on the drain point (G3/8") and fit the hose onto the drain point.
- Open the drain tap and run off the heat transfer liquid.
- Close the drain tap.



- Follow the regulations for the disposal of used heat transfer liquids.



Do not drain heat transfer liquid when it is hot or at bath temperatures below 0 °C!

### 6.3 Heat transfer liquids and hose connections

#### Heat transfer liquids

LAUDA designation	Temperature range	Chemical designation	Viscosity (kin)	Viscosity (kin) at temperature	Fire point	Packing drum Order number		
						5 L	10 L	20 L
	from °C to °C		mm <sup>2</sup> /s at 20 °C	mm <sup>2</sup> /s				
Aqua 90 ①	5...90	Decalcified water	1	--	--	LZB 120	LZB 220	LZB 320
Kryo 85	-85...30	Silicone oil	1.8	17 at -80 °C	> 56	LZB 113	LZB 213	LZB 313
Kryo 60	-60...80	Silicone oil	3	25 at -60 °C	> 110	LZB 102	LZB 202	LZB 302
Kryo 55	-50...200	Silicone oil	6	30 at -50 °C	> 160	LZB 124	LZB 224	LZB 324
Kryo 51	-50...120	Silicone oil	5	34 at -50 °C	> 160	LZB 121	LZB 221	LZB 321
Kryo 40	-40...60	Hydrous alcalisalt solution	2.36	24 at -40 °C	--	LZB 119	LZB 219	LZB 319
Kryo 30 ②	-30...90	Monoethylene glycol/ water	4	50 at -25 °C	--	LZB 109	LZB 209	LZB 309
Kryo 20	-20...180	Silicone oil	11	28 at -20 °C	> 230	LZB 116	LZB 216	LZB 316
Therm 160	60...160	Polyalkylene glycol	141	28 at 60 °C	> 273	LZB 106	LZB 206	LZB 306
Therm 180	0...180	Silicone oil	23	36 at 0 °C	> 288	LZB 114	LZB 214	LZB 314
Therm 200	60...200	Silicone oil	54	28 at 60 °C	> 362	LZB 117	LZB 217	LZB 317
Therm 240	50...240	Silicone oil	130	45 at 50 °C	> 378	LZB 122	LZB 222	LZB 322



① At higher temperatures → Evaporation losses → Use bath covers.

Only use distilled water or fully demineralized high purity water after adding 0.1 g of soda (Na<sub>2</sub>CO<sub>3</sub> sodium carbonate)/ liter of water → Risk of corrosion!

② Water content falls with longer operation at high temperatures → Mixture becomes flammable (flash point 128 °C) → Check the mixture ratio with a hydrometer.

- The use of acidic, aqueous bath liquid or cleaning agents (pH value < 7) is not permissible.
- With the selection of the heat transfer liquid, it should be noted that impairment of the properties is to be expected at the lower limit of the temperature range due to increasing viscosity. Therefore, only make maximum use of temperature ranges when essential.
- Application ranges of heat transfer liquids and hoses are general figures, which may be restricted by the operating temperature range of the units.



With silicone rubber, silicone oils lead to substantial swelling → Never use silicone oil with silicone hoses.

Safety data sheets can be ordered if required.

### Hose connections

#### a) Elastomer hoses

Hose type	Internal width Ø mm	Temperature range °C	Field of application	Order number
EPDM hose uninsulated	12	10...120	For all heat transfer liquids except Ultra 350 and mineral oils	<b>RKJ 112</b>
EPDM hose insulated	12 External Ø. approx. 35mm	-60...120	For all heat transfer liquids except Ultra 350 and mineral oils	<b>LZS 021</b>
Silicone hose uninsulated	11	-30...100	Water, Water/ glycol mixture	<b>RKJ 059</b>
Silicone hose insulated	11 External Ø. approx. 35mm	-60...100	Water, Water/ glycol mixture	<b>LZS 007</b>
Viton	11	10...200	For all heat transfer liquids	<b>RKJ 091</b>
Viton insulated	11 External Ø. approx. 32mm	-20...200	For all heat transfer liquids	<b>LZS 018</b>
 <ul style="list-style-type: none"> <li>– EPDM hose is <u>not</u> suitable for Ultra 350 and <u>not</u> suitable for mineral oils.</li> <li>– With silicone rubber, silicone oils lead to substantial swelling → never use silicone oil with silicone hoses.</li> <li>– Secure hoses against slippage with hose clips.</li> </ul>				

#### b) Metal hoses in non-rusting stainless steel with union nut M 16x1, internal width 10 mm. Recommended under certain circumstances.

Type	Length (cm)	Temperature range °C	Field of application	Order number
MK 50	50	-90...200	With foam insulation for refrigeration range, for all heat transfer liquids	<b>LZM 052</b>
MK 100	100	-90...200	"	<b>LZM 053</b>
MK 150	150	-90...200	"	<b>LZM 054</b>

## 6.4 Connecting external loads

### Operation as circulating thermostat

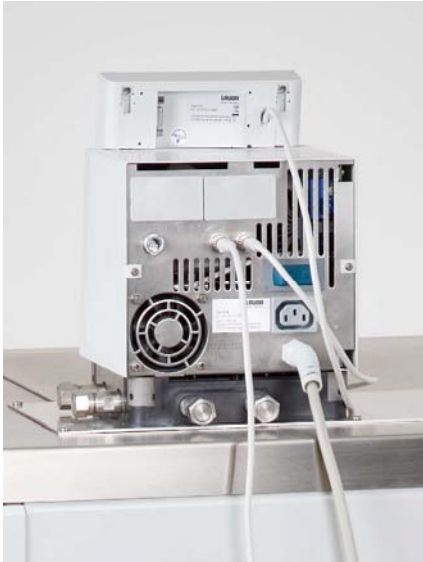

- When used as circulation thermostat, care for shortest hose connections with largest inner diameter as possible. This gives the best flow.
- Push hose with 11-12 mm internal width onto hose olive (accessories) or connect metal hoses (⇒ 6.3) to pump connectors.
- Pump connectors at side:  
Inlet and outflow ⇒ see labeling housing.
- Pump connectors at back:  
Inlet and outflow ⇒ see labeling housing.
- Set bypass valve to "external" (⇒ 3).



- The external application must not have a hydraulically blocking effect.
- If cross-sectional area of tube is too low → temperature gradient between bath and external load due to low flow rate.
- Always ensure the largest possible passages in the external circuit.
- When tightening the union nuts on the pump nipple AF 19, use a wrench AF 14 to counter the tightening torque (see figure).
- If external control is to be used, provide a Pt100 temperature probe in the external load (⇒ 7.5.2 and 7.5.4).



- With loads at a higher position and with stationary pump and ingress of air into the thermostatic circuit, the external volume can drain away, even with closed circuits → Risk of thermostat overflowing!
- Secure hoses against slippage with hose clips.
- Unused pump connectors must be closed off.

## 7 Starting up

### 7.1 Mains connection

Compare the rating on the nameplate (back of control head and behind the front panel) with the mains voltage.

**For Europe:**

Model according to EMC (Electromagnetic Compatibility) directive DIN EN 61326-1 Class B (industrial and domestic areas), if the nominal current of the current feeding point is >100 A. Otherwise only according to Class A (industrial areas only).\*

\* Notice only valid for EU countries

**Only for the USA:**

Instructions for Class A digital devices

"This equipment has been tested and found to comply with the limits for Class A digital device, pursuant to Part 15 of the FCC (Federal Communication Commission) Rules. These limits are designed to provide reasonable protection against harmful interference when the equipment is operated in a commercial environment. This equipment generates, uses, and can radiate radio frequency energy and, if not installed and used in accordance with the instruction manual, may cause harmful interference to radio communications. Operation of this equipment in a residential area is likely to cause harmful interference in which case the user will be required to correct the interference at his own expense."

"This device complies with Part 15 of the FCC (Federal Communication Commission) Rules. Operation is subject to the following two conditions: (1) This device may not cause harmful interference, and (2) this device must accept any interference received, including interference that may cause undesired operation."





**Only for Canada:**

"This Class A digital apparatus complies with Canadian ICES-003" (ICES = Interference Causing Equipment Standards).

« Cet appareil numérique de la Classe A est conforme à la norme NMB-003 du Canada ».

	<ul style="list-style-type: none"> <li>– Connect unit only to a socket with a protective earth conductor (PE).</li> <li>– No liability is accepted for incorrect mains connections.</li> <li>– Ensure that pump connectors without external loads are closed off.</li> <li>– Ensure that the unit is filled according to Section 6.2.</li> </ul>
---	--

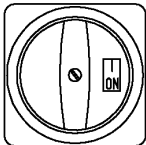

### 7.2 Switching on

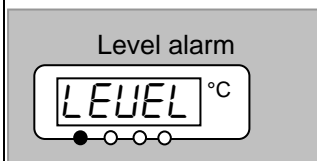
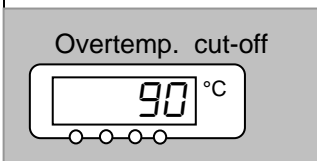
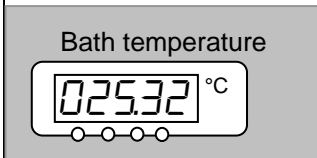
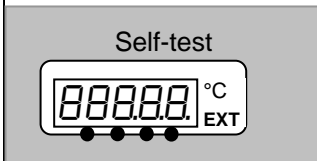
	<ul style="list-style-type: none"> <li>– Check whether the switch at the back of the master control element is in the "On = —" position.</li> </ul>
	<ul style="list-style-type: none"> <li>– Check whether the switch at the front of the master control element is in the "On = I" position.</li> </ul>
	<ul style="list-style-type: none"> <li>– Set the rotary switch on the front panel to "ON = I". The unit starts operating.</li> </ul>
	<ul style="list-style-type: none"> <li>– The green LED in the master control element for "Mains ON" is lit.</li> </ul>



- An acoustic signal is emitted for about 1 second.
- It is quite normal if the refrigerating machine makes a rattling sound for a few seconds.
- The unit starts its self-test. All display segments and symbols appear for about 1 second.
- The momentary bath temperature is displayed,
- the pump starts provided "Standby" or "Manual start" (⇒ 7.6.1) has not been programmed,
- all values are accepted which were active before switch-off.

Check or set overtemperature cut-off point:

- The switching point is shown in the LED display on pressing the key .
- Change overtemperature cut-off (⇒ 7.12.1). Overtemperature protection and checking on page 75.
- If necessary, top up heat transfer liquid, this has been pumped out by filling the external load.
- Display for **LEVEL** (low level) appears when the bath has too little liquid.
- Red LED  above the fault triangle  flashes.
- Find cause of fault and, where necessary, top up missing heat transfer liquid (⇒ 6.3).
- Press the Enter key.
- Also, press the key if unit has been switched off in the fault state.
- No release is possible on Command control element!

### Command

#### Language

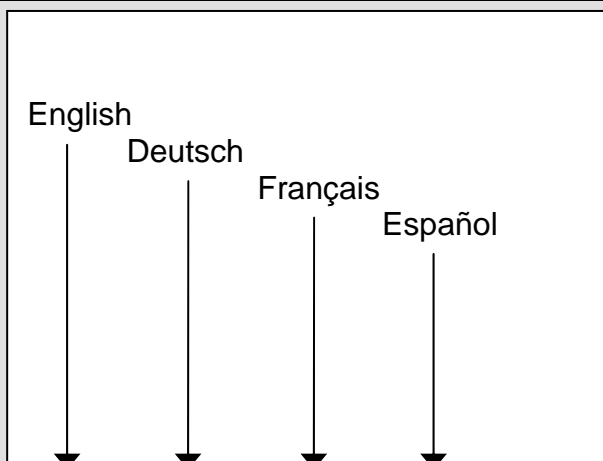

- If the Command Console is being switched on for the first time, the illustrated window appears automatically, enabling you to select the dialog language with the appropriate soft key.

Display Sounds Master Sounds Command Language Master-Mode Autostart Current Consumpt.	<table border="1" style="width: 100%; border-collapse: collapse;"> <tr><td style="background-color: black; color: white;">English</td></tr> <tr><td>Deutsch</td></tr> <tr><td>Français</td></tr> <tr><td>Español</td></tr> </table>	English	Deutsch	Français	Español	<ul style="list-style-type: none"> <li>- The dialog language also can be changed later via                      → <b>Settings</b> → <b>Basic settings</b> → <b>Language</b> .</li> <li>- Mark the required language with  or  .</li> <li>- Confirm the selection with  .</li> </ul>	
English							
Deutsch							
Français							
Español							
<table border="1" style="width: 100%; border-collapse: collapse;"> <tr> <td style="width: 15%;">Help</td> <td style="width: 15%;">Menu</td> <td style="width: 15%;">End</td> <td style="width: 15%;">T<sub>set</sub></td> <td style="width: 15%;">T<sub>fix</sub></td> </tr> </table>			Help	Menu	End	T <sub>set</sub>	T <sub>fix</sub>
Help	Menu	End	T <sub>set</sub>	T <sub>fix</sub>			

### 7.3 Switching off / standby

**Switching off:** Set the rotary switch on the front panel to "OFF = 0".

	When <u>switching off only on the master head</u> , using the switch at the front or back, there is still voltage present on the unit or head.
--	--









**Standby operation:** Use the key standby (⇒ 7.5.3) on the command control element. The pump, heating and cooling unit are switched off, but the operating display remains active, so that status displays can be viewed and settings carried out.

	However, a started timer (⇒ 7.10) continues to run. Stop as required with Pause.
--	--

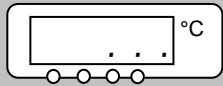
## 7.4 Key functions

Your Proline Thermostat is easy to operate. For the Command control element, you will most probably rarely need to use these operating instructions.

### 7.4.1 General key functions and pilot lamps

Master	
	<p>Enter key:</p> <ul style="list-style-type: none"> <li>- From the actual-value display at the main menu level,</li> <li>- activates input, display flashes,</li> <li>- saves input, display ceases to flash and menu point is left,</li> <li>- press for approx. 3 seconds: Exit function and returns to bath temperature display.</li> </ul>
 <span style="margin: 0 10px;">or</span> 	<ul style="list-style-type: none"> <li>- Paging with keys is possible within the relevant level, or setting of numerical values.</li> </ul> <p>Speeds up entry by moving the counting position to the left:</p> <ol style="list-style-type: none"> <li>a) Keys are pressed and held down <b>or</b></li> <li>b) one of the two keys is pressed and held down, followed immediately by brief pressing of the other key.</li> </ol> <p>Moves counting position to the right:</p> <ul style="list-style-type: none"> <li>- Switching one <b>place to the right</b> occurs by briefly (1 second) releasing the key, followed by another pressing of the key.</li> </ul>
	<p>Useful additional information:</p> <ul style="list-style-type: none"> <li>- two dots in the Master display indicate that a submenu follows.</li> <li>- Three dots in the display indicate that a submenu for a module (interface...) or a component (thermostat, Command control element ....) follows. Module/ component-specific possible settings are only displayed when the hardware is connected.</li> </ul>
	<ul style="list-style-type: none"> <li>- <b>The following always applies:</b> After termination of the relevant settings, they are accepted automatically after approx. 4 s <b>or</b></li> <li>- the setting is accepted immediately with the Enter key.</li> </ul>
 <span style="margin: 0 10px;">and</span> 	<ul style="list-style-type: none"> <li>- Fault signal: Flashing red Alarm LED and acoustic signal.</li> <li>- An acoustic signal can only sound when it has not been intentionally deactivated! (⇒ 7.6.5).</li> </ul>
	<ul style="list-style-type: none"> <li>- The bath control occurs via the external temperature probe when the green LED is lit.</li> </ul>
	<ul style="list-style-type: none"> <li>- Heating is active when the yellow LED is lit.</li> </ul>
	<ul style="list-style-type: none"> <li>- Cooling is active. When the setpoint temperature is lowered, it may take up to one minute before the blue LED is lit.</li> </ul>
<b>EXT</b>	<ul style="list-style-type: none"> <li>- The temperature of the external probe is displayed.</li> </ul>

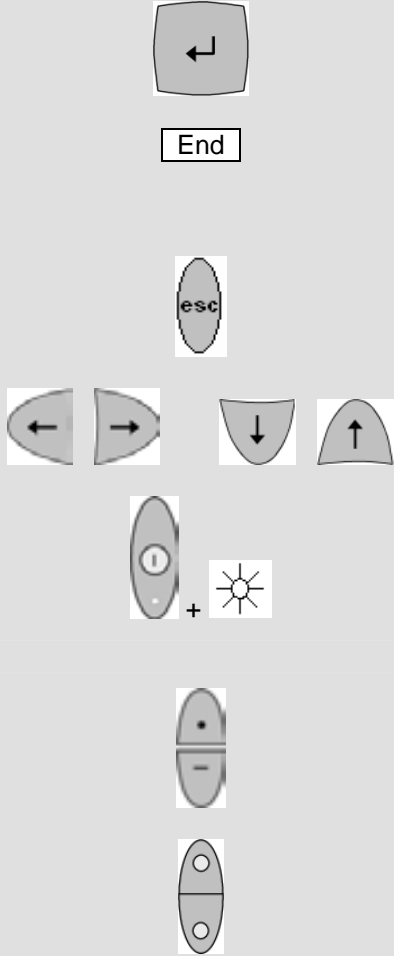
Command						
	<ul style="list-style-type: none"> <li>- Enter key ("Confirm selection") and go back one level.</li> <li>- Soft key function, to confirm a selection or input and to return to the main display window.</li> <li>- Escape key to quit a window without changes and to go back one level.</li> <li>- Cursor keys for Up, Down, Left and Right.</li> <li>- Standby activation (pump, heater and refrigerating machine are deactivated when the yellow LED is lit). However, timer continues to run! Refer to safety information in ⇒ 7.5.3.</li> </ul> <p>Duo key:</p> <ul style="list-style-type: none"> <li>- Top: decimal-point key.</li> <li>- Bottom: key for arithmetical sign.</li> </ul> <p>- Soft keys: five duo-keys, which each have the function shown in display above them. Soft-key entries are shown framed in the operating instructions. Example: You would like to change the setpoint temperature then press the duo-key under <span style="border: 1px solid black; padding: 2px;">T<sub>set</sub></span>.</p>					
<table border="1" style="width: 100%; border-collapse: collapse;"> <tr> <td style="width: 50%; padding: 5px;"> <div style="border: 1px solid black; padding: 2px; margin-bottom: 5px;">Display</div>                 Sounds Master                  Sounds Command                  Language                  Master Mode                  Autostart                  Current Consumpt.             </td> <td style="width: 50%; padding: 5px;"> <div style="border: 1px solid black; padding: 2px; margin-bottom: 5px; background-color: black; color: white;">Brightness</div>                 Contrast             </td> </tr> </table>	<div style="border: 1px solid black; padding: 2px; margin-bottom: 5px;">Display</div> Sounds Master Sounds Command Language Master Mode Autostart Current Consumpt.	<div style="border: 1px solid black; padding: 2px; margin-bottom: 5px; background-color: black; color: white;">Brightness</div> Contrast	<ul style="list-style-type: none"> <li>- <span style="background-color: black; color: white; padding: 2px;">Brightness</span> <span style="background-color: black; color: white; padding: 2px;">Contrast</span></li> <li>- The brightness and contrast can be set on the Command Console:</li> <li>- The works setting can be changed via → <span style="background-color: black; color: white; padding: 2px;">Settings</span> → <span style="background-color: black; color: white; padding: 2px;">Basic settings</span> → <span style="background-color: black; color: white; padding: 2px;">Display</span> → <span style="background-color: black; color: white; padding: 2px;">Brightness</span> or → <span style="background-color: black; color: white; padding: 2px;">Contrast</span>.</li> <li>- The brightness of the LCD illumination can be selected from eight steps or switched off completely.</li> <li>- The contrast can be set in eight steps.</li> </ul>			
<div style="border: 1px solid black; padding: 2px; margin-bottom: 5px;">Display</div> Sounds Master Sounds Command Language Master Mode Autostart Current Consumpt.	<div style="border: 1px solid black; padding: 2px; margin-bottom: 5px; background-color: black; color: white;">Brightness</div> Contrast					
<table border="1" style="width: 100%; border-collapse: collapse; text-align: center;"> <tr> <td style="padding: 5px;">Help</td> <td style="padding: 5px;">Menu</td> <td style="padding: 5px;">End</td> <td style="padding: 5px;">T<sub>set</sub></td> <td style="padding: 5px;">T<sub>fix</sub></td> </tr> </table>	Help	Menu	End	T <sub>set</sub>	T <sub>fix</sub>	<ul style="list-style-type: none"> <li>- There are four different screen displays available.</li> </ul> <p>The screen is switched over with the soft key <span style="border: 1px solid black; padding: 2px;">Screen</span> :</p>
Help	Menu	End	T <sub>set</sub>	T <sub>fix</sub>		

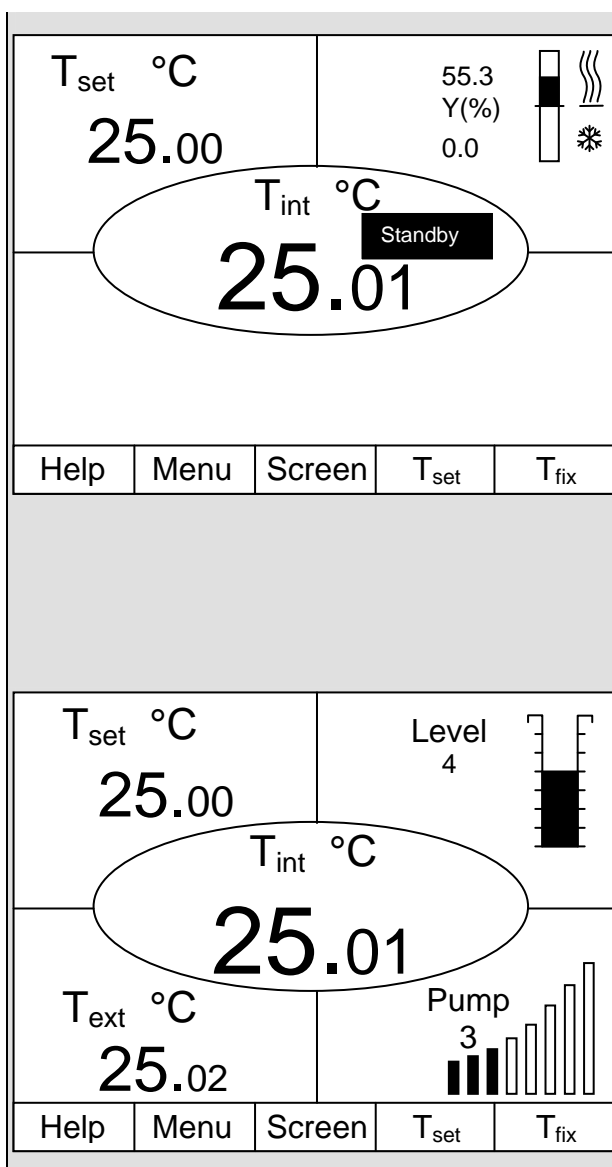

**1. Basic window** with the three most important items of information:

- $T_{int}$ , current bath temperature,
- $T_{set}$ , setpoint of the bath or external temperature,
- Information: Heating/ cooling. Here, e.g. heating is taking place at 55.3% and 0.0% cooling.

Soft keys:

- Help: Help function.
- Menu: Set unit parameters.
- Screen: Changes between basic, normal, super and graphics recorder windows.
- $T_{set}$ : Changes setpoint temperature.
- $T_{fix}$ : Calling and setting of saved setpoints.

**2. Standard window** with five important items of information:

- $T_{int}$ , current bath temperature,
- $T_{set}$ , setpoint,
- $T_{ext}$ , current temperature on external probe (if connected),
- Level of heat transfer liquid in cm above the minimum level,
- Pump level of the VarioFlex Pump.
- Soft keys like above.

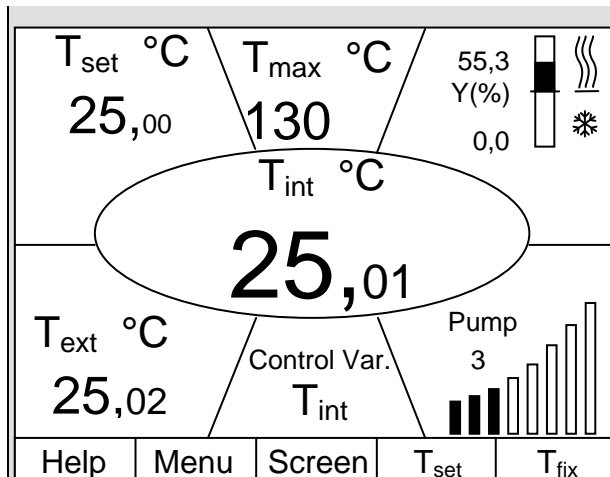

### 3. Super window with seven items of information:

- $T_{int}$ , current bath temperature.
- $T_{set}$ , setpoint.
- $T_{ext}$ , current temperature on external probe (if connected).
- Overtemperature cut-off point  $T_{max}$ .
- Pump level of the VarioFlex Pump.
- Control variable to  $T_{int}$  or  $T_{ext}$ .
- Information: Heating / cooling.

Soft keys like above.

### 4. Graphical measurement display

- All temperature values can be shown graphically against time  $\Rightarrow$  7.7.
- Soft keys like above.

## 7.4.2 Changing window information (Command Console)

Command
– **Display data**

$T_{set}$ °C <b>25.00</b>	Level 4			
$T_{int}$ °C <b>25.01</b>				
$T_{ext}$ °C <b>25.02</b>	Pump 3			
Help	Menu	Screen	$T_{set}$	$T_{fix}$

- You can adapt the information displayed by your Command Console to your requirements. For example, if you have not connected any temperature probe, you can exchange it in the standard setting of the normal window for the maximum temperature  $T_{max}$  (safety cut-off).
- This is how it is done:

- Open the unit parameter menu via the soft key **Menu**.

- With and change from
 

Settings	→
Display Data	→
Standard Window	→
Edit	

- or takes you to the illustrated window.

- and marks **T max** as illustrated.

- Confirm selection with or **End**,





- or quit the window with without any changes being made.

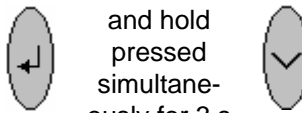
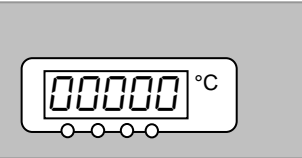
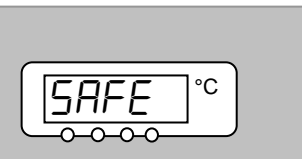
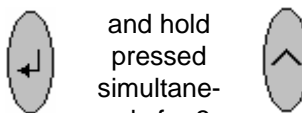
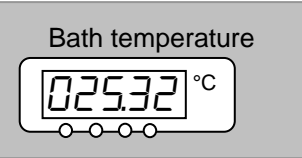

Basic Window	<b>Edit</b>			
Standard Window	Default			
Super Window				
Help	Menu	End	$T_{set}$	$T_{fix}$

Center	$T$ internal			
Up left	$T$ external			
Up right	Setpoint			
Down left	<b><math>T</math> max</b>			
Down right	Pump step			
	Set value			
	Level			
	Control variable			
	Date/time			
	Programmer			
Help	Menu	End	$T_{set}$	$T_{fix}$





**7.4.3 Locking the keyboard**

The keyboards of the Master and the Command control element can be locked independently of one another. This is especially advantageous when the thermostat is positioned in another room and the Command control element is used as a remote control device. Then the Master keyboard can be locked to prevent unintentional adjustment.

<p><b>Master</b></p>     	<p>– <i>SAFE</i></p> <p><b>Locking:</b></p> <ul style="list-style-type: none"> <li>– <i>SET</i> appears for 3 seconds,</li> <li>– then the segments of the first right-hand  are formed,</li> <li>– hold both keys pressed until this display is <u>completely</u> visible.</li> </ul> <p>– <i>SAFE</i> flashes briefly and the display returns to the actual temperature.</p> <ul style="list-style-type: none"> <li>– The Master keyboard is now locked.</li> <li>– The <i>SAFE</i> display signals the locked state when any Master key is pressed.</li> </ul> <p><b>Unlocking:</b></p> <ul style="list-style-type: none"> <li>– For three seconds, then <i>SAFE</i> appears.</li> <li>– Then the segments of the left-hand  are formed.</li> <li>– The actual bath temperature appears again when all the s have been formed.</li> </ul>
---	---

Command				
<div style="border: 1px solid black; padding: 10px; margin: 10px auto; width: 80%;"> <p style="text-align: center;">Locking keyboard</p>  </div>				
Help	Menu	End	T <sub>set</sub>	T <sub>fix</sub>
<div style="border: 1px solid black; padding: 10px; margin: 10px auto; width: 80%;"> <p style="text-align: center;">Unlocking keyboard</p>  </div>				

**Locking:**







- Press  and then  and hold pressed simultaneously for three seconds.
- The locking window appears.
- Hold both keys pressed until the progress bar is completely filled.
- Then the display skips back to the previously set Screen mode.
- The soft-key boxes are now blank, indicating that the keyboard is locked.
- On pressing any Master key the display appears:  
Keyboard locked
- Unlocking:
- Press  and then  and hold pressed simultaneously for three seconds.
- The unlocking window appears.
- Hold both keys pressed until the progress bar is completely filled.

Then the display skips back to the previously set Screen mode.

## 7.5 Important settings

### 7.5.1 Temperature setpoint setting

The setpoint is the temperature, which the thermostat should reach and maintain constant.

<b>Master</b> (main level)	– <i>SEt</i>
	– Press key until <i>SEt</i> (Setpoint) appears.
	– Press key, display flashes.
 or 	– Enter the setpoint with the two keys (⇒ 7.4.1 General key functions and pilot lamps).
Wait 4 seconds or 	– Display flashes 4 seconds → new value is automatically accepted, <b>or</b> value is accepted immediately with Enter key.
	– For safety reasons the setpoint can only be set up to 2°C above upper limit of the operating temperature range for the relevant device type.
	– In the following cases, the manual setpoint entry is blocked: Setpoint is taken from the analog module, from the programmer in the Command Console or via the serial interface.
	– When the setpoint temperature is to be lowered, it may take up to one minute before the blue LED  lights.

Command
– T<sub>set</sub> or T<sub>fix</sub>

Enter new setpoint:

123,45

Min: -40.00°C Max:202.00°C

1	2	3	4	5
6	7	8	9	0

Fixed settings	Recent setpoints
0.00°C	80.00°C
0.00°C	-35.50°C
0.00°C	20.00°C
0.00°C	38.00°C
0.00°C	-35.70°C
0.00°C	0.00°C
0.00°C	0.00°C
0.00°C	0.00°C

Help	Menu	End	T <sub>set</sub>	Edit
------	------	-----	------------------	------

– Confirm the value with or quit the window with without having made any changes.

Two other ways of entering the setpoint:

- With the soft key T<sub>fix</sub> open the window shown on the left.
- The setpoints, which you last entered, are shown in the right-hand column. In the illustrated screen, the last setpoint was 80.0 °C.
- To accept an earlier setpoint, enter the right-hand column with and select the desired value with , then accept it with or cancel with .
- In the left-hand column setpoint temperatures, which are to be used frequently, can be defined as “fixed settings”.

Enter new setpoint:

123.45

Min: -40.00°C Max:202.00°C

1	2	3	4	5
6	7	8	9	0

- Select desired position with the cursor keys (black background).
- With the soft key **Edit** open the window shown on the left.
- Enter fixed temperature setpoint as described above and accept into the list with or cancel with .
- Select and accept values from the list of fixed settings as described above for the "Recent setpoints".

### 7.5.2 Displaying the actual external temperature

With all Proline Thermostats an external temperature probe can be connected, which for example....

1. ...can be used as an independent temperature measurement channel.
2. ...can be used as the controlled variable for the bath temperature in applications with a noticeable temperature gradient (between the internal bath temperature and an external load). The setup is described in Section 7.5.4. With the function described in the following, you only change over the display.



- External actual temperatures can also be read in by interface modules ⇒ 8.

Connection of the external Pt100 to the Lemo socket 10S

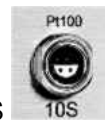

Contact on socket 10S

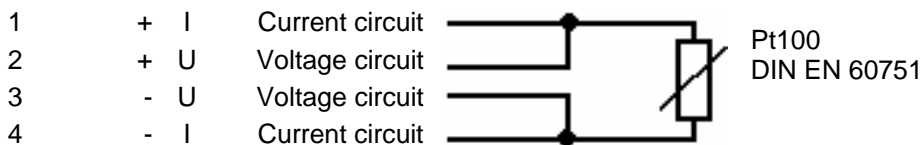

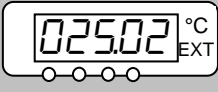
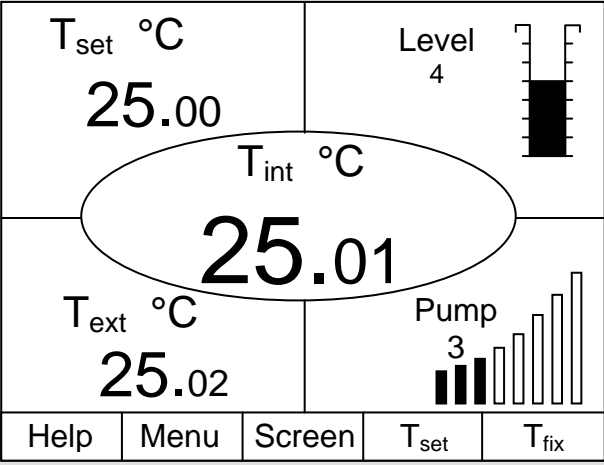

- Plug: 4-pole Lemosa for Pt100 connection (Order No. EQS 022).
- Use screened connecting leads. Connect screen to plug case.

<p><b>Master</b></p> <p>↑ or ↓</p> 	<p>– <b>EXT</b></p> <p>– Switches to the actual-value display of the external temperature probe (or to the actual value received from an interface module ⇒ 7.5.4).</p> <p>– <b>EXT</b> is lit in green next to the row of figures.</p> <p>– If no external Pt100 probe is connected, ----- is displayed.</p>
<p><b>Command</b></p> 	<p>– <b>T<sub>ext</sub></b></p> <p>– Provided an external temperature probe is connected, its value is displayed in the lower left part of the standard and super windows (applies to the works setting for the window partitioning).</p> <p>– <b>External actual temperatures can also be read in via interface modules</b> ⇒ 8.</p>

### 7.5.3 Setting pump power or standby

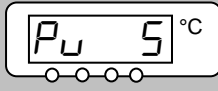
With the Proline VarioFlex pump, four pump levels (level five till level eight) are available, with which the bath circulation, flow rate and pressure, the noise generated and the mechanical heat input can be optimized. Pump level eight gives the best bath circulation and temperature homogeneity.



<p><b>Master</b></p> <p>← and 1 x ↓</p>  <p>↑ or ↓</p>	<p>– <b>P<sub>U</sub></b></p> <p>– Call pump power levels display <b>P<sub>U</sub></b>.</p> <p>– The current pump level is displayed (here <b>5</b>).</p> <p>– The pump levels display flashes.</p> <p>– Select pump level (pump speed = pump power):</p> <p><b>5</b> to <b>8</b> for pump operation. Pump responds immediately!</p> <p>– <b>0</b> activates the standby function (pump, heater and refrigerating machine are deactivated).</p>
---	---









Wait 4 seconds or  – Display flashes 4 s → new value is automatically accepted, **or**  
 – value is immediately accepted with Enter key.

**Command**

Pump Level	Level 8
	Level 7
	Level 6
	Level 5
	Level 4
	Level 3
	Level 2
	Level 1

Help Menu End T<sub>set</sub> T<sub>fix</sub>

 + 

- **Pump Level**
- Open the device parameter menu via the soft key  Menu .
- Change from **Pump** → **Pump Level** using  .
- With  or  you enter the illustrated window. **Level 5** is active.
- Select another pump level with  or  and confirm with  or End ,
- or quit the window with  without making any changes.
- It is not possible to select the pump levels 1 to 4.

**Standby activation**

- Standby activation (Pump, heater and refrigerating machine are deactivated when the green LED in the lower part of the key is lit).



Please exercise caution when thermostat is in standby mode. The following settings/ actions may start the thermostat unintentionally from the standby mode:

- a previously activated timer mode (⇒ 7.10), because a started timer continues to run!
- “Start” command via interfaces (⇒ 8).

### 7.5.4 Activate external pump

As an option an external pump is available for the Proline Kryomats for external applications. This pump can be set on / off manually in the menu shown below. Another possibility is the automatic mode. In this case the pump is switched according to the unit status standby / running.

Command	Ext. Pump
<div style="border: 1px solid black; padding: 5px; margin-bottom: 5px;"> <span style="border: 1px solid black; padding: 2px;">Ext. pump</span> <div style="display: inline-block; vertical-align: top; padding-left: 10px;"> <div style="background-color: black; color: white; padding: 2px; margin-bottom: 5px;">off</div> <div style="padding: 2px;">on</div> <div style="padding: 2px;">auto.</div> </div> </div> <div style="display: flex; justify-content: space-between; margin-top: 5px;"> <span>Help</span> <span>Menu</span> <span>End</span> <span>T<sub>set</sub></span> <span>T<sub>fix</sub></span> </div>	<ul style="list-style-type: none"> <li>- Open the device parameter menu via the soft key  <span style="border: 1px solid black; padding: 2px;">Menu</span> .</li> <li>- Change from <b>Pump</b> → <b>Ext. pump</b> using  .</li> <li>- With  or  you enter the illustrated window.</li> <li>- Use  or  to switch the pump off, permanently on or to set the automatic mode. Confirm your selection with  or <span style="border: 1px solid black; padding: 2px;">End</span> ,</li> <li>- or quit the window with  without making any changes.</li> <li>- Automatic mode means that the external pump is switched off while the unit is in standby mode or it is switched on while the unit is running.</li> </ul>

### 7.5.5 Activating external control

An external temperature probe can be connected to the Proline Thermostats. How this is done is explained in Section 7.5.2. If the bath temperature is to be controlled using this sensor instead of the internal sensor, the setting can be made here.

Furthermore, control can also occur based on the signal from the analog or serial module (⇒ 4.8).

Master	Con
<div style="text-align: center; margin-bottom: 10px;">  and 2 x  </div> <div style="border: 1px solid black; padding: 5px; margin-bottom: 10px; text-align: center;"> <span style="border: 1px solid black; padding: 2px;">Con</span> 1 °C         </div> <div style="text-align: center;"> </div>	<ul style="list-style-type: none"> <li>- Call the source selection for the control <b>Con</b> .</li> <li>- The momentary setting for the source is displayed,</li> <li>- here <b>1</b> for internal, because control takes place using the temperature signal from the internal temperature probe.</li> <li>- The source display flashes.</li> </ul>

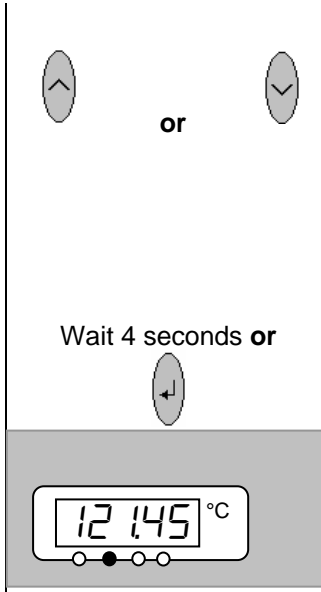

↑ or ↓





Wait 4 seconds or ↵

12.145 °C

- Change temperature probe source:
- *I* for the internal probe,
- *EP* only when an external probe is connected,
- *EA* only when an analog module is connected and configured,
- *ES* only when a serial module is connected and is continuously receiving actual values from a PC.
- Display flashes 4 s → new value is automatically accepted, or
- value is immediately accepted with Enter key.
- If *EP EA* or *ES* has been selected, then the green  LED indicates that the control has regulated to the external temperature signal.

**Command**

Control Variable	<div style="border: 1px solid black; padding: 2px;">intern</div> External Pt100 Analog module Digital module			
Help	Menu	End	T <sub>set</sub>	T <sub>fix</sub>

- **Control Variable**
- Open the device parameter menu with the soft key  Menu .
- With the cursor keys, change further to → **Control** → **Control Variable** .
- **intern** is currently active.
- Select other control variables (only displayed when present) with  or  and confirm with  or **End** ,
- or quit the window with  without making any changes.

## 7.5.6 Current consumption from the mains



It is not possible to reduce the power consumption of the Proline Kryomats!

Command				
Display Sounds Master Sounds Command Language Master Mode Autostart Current consumpt.				
<div style="border: 1px solid black; padding: 5px; width: fit-content; margin: 0 auto;">16.0 A</div>				
Help	Menu	End	T <sub>set</sub>	T <sub>fix</sub>
<div style="border: 1px solid black; padding: 10px; width: fit-content; margin: 0 auto;">           Max. current consumption (in A):   <div style="font-size: 2em; font-weight: bold; text-align: center;">16.0</div> <hr style="width: 20%; margin: 0 auto;"/>           Min: 10.0 A    Max: 16.0 A         </div>				
1	2	3	4	5
6	7	8	9	0

**Current Consumption**

- Open the device parameter menu via the soft key  **Menu** .
- With the cursor keys change further to → **Settings** → **Basic settings** → **Current Consumpt.** .
- **16.0 A** is active.



- Open the settings window with  .
- Changes are not accepted!
- Quit the window with  .

**7.5.7 Setting the date and time (Command)**

<b>Command</b>				
Pump Settings Graph <span style="border: 1px solid black; padding: 2px;">Clock</span> Programmer Interfaces Control Limits	<div style="border: 1px solid black; padding: 5px;"> <p><b>Set time</b>                      Set date                      Timer 1                      Timer 2                      Format of date</p> </div>			
Help	Menu	End	T <sub>set</sub>	T <sub>fix</sub>
<div style="border: 1px solid black; padding: 10px; width: fit-content; margin: 0 auto;">                 Enter time:   <div style="font-size: 2em; font-weight: bold; text-align: center;">15:38:12</div> </div>				
1	2	3	4	5
6	7	8	9	0

- **Clock** **Time** **Date**
- Open the device parameter menu via the soft key  **Menu**.
- With the cursor keys continue to:  
 → **Clock** → **Set time**,
- or to **Set date**.





  

- Open the settings window with .
- Change the time with cursor or soft keys and accept with .
- or quit the window with  without making changes.
- The date is set just the same with **Set date**.
- The date format (Day Month Year or Month Day Year) can be set under **Format of date**.

## 7.5.8 Display resolution setting (Command)

The Command version allows for different resolutions of the displayed temperature.







Command												
Pump Settings Graph Clock Programmer Interfaces Control Limits	Calibration Works settings <b>Resolution</b> Device status Display data Basic settings Overlevel handling											
Help	Menu	End	T <sub>set</sub>	T <sub>fix</sub>								
<table border="1" style="width: 100%; border-collapse: collapse;"> <thead> <tr> <th style="text-align: left; padding: 5px;">Resolution</th> <th style="padding: 5px;"></th> </tr> </thead> <tbody> <tr> <td style="padding: 5px;"></td> <td style="padding: 5px;">0,1</td> </tr> <tr> <td style="padding: 5px;"></td> <td style="padding: 5px;">0,01</td> </tr> <tr> <td style="padding: 5px;"></td> <td style="padding: 5px;"><b>0,001</b></td> </tr> </tbody> </table>					Resolution			0,1		0,01		<b>0,001</b>
Resolution												
	0,1											
	0,01											
	<b>0,001</b>											
Help	Menu	End	T <sub>set</sub>	T <sub>fix</sub>								

- **Display resolution**
- Open the device parameter menu via the soft key  **Menu**.
- With the cursor keys continue to → **Settings** → **Display resolution**.
- Select the desired resolution with  or .
- Accept selection with  or **End**, or quit the window with  without making any changes.

## 7.6 Special settings

### 7.6.1 Defining the type of start mode

Usually it is desirable that the thermostat carries on operating again after an interruption in the voltage supply. However, if for safety reasons you do not wish this, you can insert an intervening manual activation step.







Command				
<div style="display: flex; justify-content: space-between;"> <div style="border: 1px solid black; padding: 5px; width: 40%;"> <p>Display</p> <p>Sounds Master</p> <p>Sounds Command</p> <p>Language</p> <p>Master Mode</p> <p style="border: 1px solid black;">Autostart</p> <p>Current consumpt.</p> </div> <div style="border: 1px solid black; padding: 5px; width: 40%;"> <p>Off</p> <p style="background-color: black; color: white;">On</p> </div> </div>				
Help	Menu	End	$T_{set}$	$T_{fix}$
<ul style="list-style-type: none"> <li>- <b>Auto start</b></li> <li>- Open the device parameter menu via the soft key  <span style="border: 1px solid black; padding: 2px;">Menu</span> .</li> <li>- With the cursor keys continue to:                       → <b>Settings</b> → <b>Basic settings</b> → <b>Auto start</b> .</li> <li>- <b>On</b> is currently active.</li> <li>- If the standby mode is to be activated after a mains interruption, activate "Off" with  or  .</li> <li>- Accept the change with  or <span style="border: 1px solid black; padding: 2px;">End</span> ,</li> <li>- or quit the window with  without making changes.</li> </ul>				
<p> - When the mains voltage has been restored after an interruption, you can quit the standby mode with  .</p>				

## 7.6.2 Defining temperature limits

With this function, it is possible to define a minimum and a maximum temperature in which the thermostat controls. By reaching the temperature limits, a warning appears. In this way setpoint input can be prevented which may damage the heat transfer liquid or the apparatus. For example, if water were used as the heat transfer liquid, +95 °C would be practicable as the maximum temperature and +5 °C as the minimum temperature.

Command				
Pump	<div style="border: 1px solid black; padding: 5px;"> <p>T il (min) -50.0 °C T ih (max) 90.0 °C</p> </div>			
Settings				
Graph				
Clock				
Programmer				
Interfaces				
Control				
Limits				
Help	Menu	End	T <sub>set</sub>	T <sub>fix</sub>
<div style="border: 1px solid black; padding: 10px; margin: 10px auto; width: 80%;"> <p>Lower limit (T il)</p> <p style="font-size: 2em; font-weight: bold; text-align: center;">-50.0</p> <hr style="width: 20%; margin: 0 auto;"/> <p>Min: -100.0 °C    Max: 202.0 °C</p> </div>				
1	2	3	4	5
6	7	8	9	0

**Limits**

- Open the device parameter menu via the soft key  **Menu** .
- With the cursor keys continue to **Limits** .
- The minimum and maximum temperatures are displayed.
- **T il (min)** is currently active.
- Select the limit to be changed with  or  and confirm with  .
- Enter the desired limit temperature.
- Accept the change with  ,
- or quit the window with  without making changes.

### 7.6.3 Setpoint offset operating mode

With this function it is possible to apply an offset value to the temperature provided by the external temperature probe or a module and then to use it as the setpoint. The bath temperature can, for example, be operated at -25 °C below the temperature of a reactor, which is being measured by the external temperature probe.

<div style="border: 1px solid black; padding: 5px;"> <p><b>Command</b></p> <table style="width: 100%; border-collapse: collapse;"> <tr> <td style="width: 30%; border: 1px solid black; padding: 2px;">Offset source</td> <td style="border: 1px solid black; padding: 2px;">Off</td> </tr> <tr> <td style="border: 1px solid black; padding: 2px;">Setpoint offset</td> <td style="border: 1px solid black; padding: 2px;">extern Pt100 RS232</td> </tr> </table> <table style="width: 100%; border-collapse: collapse; margin-top: 5px;"> <tr> <td style="border: 1px solid black; padding: 2px;">Help</td> <td style="border: 1px solid black; padding: 2px;">Menu</td> <td style="border: 1px solid black; padding: 2px;">End</td> <td style="border: 1px solid black; padding: 2px;">T<sub>set</sub></td> <td style="border: 1px solid black; padding: 2px;">T<sub>fix</sub></td> </tr> </table> </div>	Offset source	Off	Setpoint offset	extern Pt100 RS232	Help	Menu	End	T <sub>set</sub>	T <sub>fix</sub>	<ul style="list-style-type: none"> <li>- <b>Offset source</b> and <b>Setpoint offset</b></li> <li>- Open the device parameter menu via the soft key  <b>Menu</b> .</li> <li>- With the cursor keys continue to → <b>Control</b> → <b>Setpoint offset</b> → <b>Offset source</b> .</li> <li>- <b>Off</b> indicates that the setpoint offset is currently deactivated.</li> <li>- Select the setpoint source with  or  and confirm with  .</li> <li>- Interfaces (e.g. RS232) are only displayed if a valid setpoint has already been transmitted.</li> </ul>	
Offset source	Off										
Setpoint offset	extern Pt100 RS232										
Help	Menu	End	T <sub>set</sub>	T <sub>fix</sub>							
<div style="border: 1px solid black; padding: 5px;"> <table style="width: 100%; border-collapse: collapse;"> <tr> <td style="width: 30%; border: 1px solid black; padding: 2px;">Offset source</td> <td style="border: 1px solid black; padding: 2px;"><b>0.00 °C</b></td> </tr> <tr> <td style="border: 1px solid black; padding: 2px;">Setpoint offset</td> <td style="border: 1px solid black; padding: 2px;"></td> </tr> </table> <table style="width: 100%; border-collapse: collapse; margin-top: 5px;"> <tr> <td style="border: 1px solid black; padding: 2px;">Help</td> <td style="border: 1px solid black; padding: 2px;">Menu</td> <td style="border: 1px solid black; padding: 2px;">End</td> <td style="border: 1px solid black; padding: 2px;">T<sub>set</sub></td> <td style="border: 1px solid black; padding: 2px;">T<sub>fix</sub></td> </tr> </table> </div>	Offset source	<b>0.00 °C</b>	Setpoint offset		Help	Menu	End	T <sub>set</sub>	T <sub>fix</sub>	<ul style="list-style-type: none"> <li>- With the cursor keys continue to → <b>Setpoint offset</b> .</li> <li>- The standard value is <b>0.00°C</b> .</li> </ul>	
Offset source	<b>0.00 °C</b>										
Setpoint offset											
Help	Menu	End	T <sub>set</sub>	T <sub>fix</sub>							
<div style="border: 1px solid black; padding: 5px;"> <div style="border: 1px solid black; padding: 10px; text-align: center;"> <p>Input Setpoint offset:</p> <p style="font-size: 2em; margin: 0;"><b>0.00</b></p> <hr style="width: 50%; margin: 5px auto;"/> <p>Min: -500.00°C Max: 500.00°C</p> </div> <table style="width: 100%; border-collapse: collapse; margin-top: 5px;"> <tr> <td style="border: 1px solid black; padding: 2px;">1</td> <td style="border: 1px solid black; padding: 2px;">2</td> <td style="border: 1px solid black; padding: 2px;">3</td> <td style="border: 1px solid black; padding: 2px;">4</td> <td style="border: 1px solid black; padding: 2px;">5</td> </tr> <tr> <td style="border: 1px solid black; padding: 2px;">6</td> <td style="border: 1px solid black; padding: 2px;">7</td> <td style="border: 1px solid black; padding: 2px;">8</td> <td style="border: 1px solid black; padding: 2px;">9</td> <td style="border: 1px solid black; padding: 2px;">0</td> </tr> </table> </div>	1	2	3	4	5	6	7	8	9	0	<ul style="list-style-type: none"> <li>- Open the left-hand window with  .</li> <li>- Enter the desired temperature.</li> <li>- Accept the change with  ,</li> <li>- quit the window with  without making changes.</li> </ul>
1	2	3	4	5							
6	7	8	9	0							

## 7.6.4 Restoring works settings

All works settings, apart from the control parameters and the sensor calibration, are restored.







Command				
<p>All modules Master Command Cool</p>		<p>all default <b>only control par. int</b> only control par. ext only miscellaneous</p>		
Help	Menu	End	T <sub>set</sub>	T <sub>fix</sub>

<p>Confirm input!</p> <p>Enter key: Continue</p> <p>Escape key: Cancel</p>				
Help	Menu	End	T <sub>set</sub>	T <sub>fix</sub>





  

**Works settings**

- Open the device parameter menu via the soft key  **Menu** .
- With the cursor keys continue to → **Settings** → **Works settings** .
- The window shown opposite appears.
- **Master** and then **only control par. int.** is shown as a possible choice. There are however various possibilities, which can be selected with  or  .
- Under **All modules** Master, Command and all connected modules are reset to the works setting with **all default** .
- Under **Master** you have the choice between:
  - **all default** , then all Master settings are reset,
  - **only control para. int.** for the internal control parameters,
  - **only control para. ext.** similar for external,
  - **only miscellaneous** which resets setpoint, pump level, maximum current consumption, control to internal and auto start to "Auto".
- Under **Command** all command settings are reset with **All default** .
- Confirm selection with  .
- Confirm the control dialog shown on the left with  or cancel with  .
- Return to measurement window with **End** or  .



### 7.6.5 Setting the volume of the acoustic signals

The LAUDA Proline Thermostats signal alarms as a dual-tone acoustic signal and warnings as a continuous tone.



<p><b>Command</b></p> <div style="border: 1px solid black; padding: 5px; margin: 10px 0;"> <table style="width: 100%; border-collapse: collapse;"> <tr> <td style="border: 1px solid black; padding: 2px;">Alarm</td> <td style="border: 1px solid black; padding: 2px;">loud</td> </tr> <tr> <td style="border: 1px solid black; padding: 2px;"></td> <td style="border: 1px solid black; padding: 2px;">medium</td> </tr> <tr> <td style="border: 1px solid black; padding: 2px;"></td> <td style="border: 1px solid black; padding: 2px;">low</td> </tr> <tr> <td style="border: 1px solid black; padding: 2px;"></td> <td style="border: 1px solid black; padding: 2px;">off</td> </tr> </table> </div> <table border="1" style="width: 100%; border-collapse: collapse; margin-top: 5px;"> <tr> <td style="padding: 2px;">Help</td> <td style="padding: 2px;">Menu</td> <td style="padding: 2px;">End</td> <td style="padding: 2px;">T<sub>set</sub></td> <td style="padding: 2px;">T<sub>fix</sub></td> </tr> </table>	Alarm	loud		medium		low		off	Help	Menu	End	T <sub>set</sub>	T <sub>fix</sub>	<p>– <b>Sounds</b></p> <ul style="list-style-type: none"> <li>– Open the device parameter menu via the soft key  <b>Menu</b> .</li> <li>– With the cursor keys continue to → <b>Settings</b> → <b>Basic Settings</b> → <b>Sounds</b> .</li> <li>– Select either <b>Alarm</b> or <b>Warning</b> .</li> <li>– Example on left: <b>Alarm</b> is set to loud.</li> <li>– Select the desired volume with  or  .</li> <li>– Accept selection with  or <b>End</b> or quit the window with  without making changes.</li> </ul>
Alarm	loud													
	medium													
	low													
	off													
Help	Menu	End	T <sub>set</sub>	T <sub>fix</sub>										

### 7.6.6 Entering the offset of the internal temperature probe

If, during checking with a calibrated reference thermometer (e.g. from the LAUDA DigiCal Series) a deviation is found, then the offset (i.e. the additive part of the characteristic) of the internal measuring chain can be adjusted with the following function. The reference thermometer must be dipped into the bath according to the details on the calibration certificate.

<p><b>Command</b></p> <div style="border: 1px solid black; padding: 5px; margin: 10px 0;"> <table style="width: 100%; border-collapse: collapse;"> <tr> <td style="border: 1px solid black; padding: 2px;">intern Pt100</td> <td style="border: 1px solid black; padding: 2px;">Calibration</td> </tr> <tr> <td style="border: 1px solid black; padding: 2px;">extern Pt100</td> <td style="border: 1px solid black; padding: 2px;">Default</td> </tr> </table> </div> <table border="1" style="width: 100%; border-collapse: collapse; margin-top: 5px;"> <tr> <td style="padding: 2px;">Help</td> <td style="padding: 2px;">Menu</td> <td style="padding: 2px;">End</td> <td style="padding: 2px;">T<sub>set</sub></td> <td style="padding: 2px;">T<sub>fix</sub></td> </tr> </table>	intern Pt100	Calibration	extern Pt100	Default	Help	Menu	End	T <sub>set</sub>	T <sub>fix</sub>	<p>– <b>Calibration</b></p> <ul style="list-style-type: none"> <li>– Open the device parameter menu via the soft key  <b>Menu</b> .</li> <li>– With the cursor keys continue to → <b>Settings</b> → <b>Calibration</b> → <b>intern Pt100</b> → <b>Calibration</b> .</li> <li>– The window shown on the left appears.</li> <li>– Confirm selection with  .</li> </ul>
intern Pt100	Calibration									
extern Pt100	Default									
Help	Menu	End	T <sub>set</sub>	T <sub>fix</sub>						

Temperature value of the ref. temp. measurement device:  <div style="font-size: 2em; font-weight: bold; text-align: center;">20.15</div> Min: -50.0°C    Max: 302.00				
1	2	3	4	5
6	7	8	9	0

- The temperature measurement device shows the true temperature value (with glass thermometers consider the correction where applicable!).
- Change the display in the adjacent window to the true value with cursor or soft keys and accept with  or **End** ,
- or quit the window with  without making changes.

### 7.6.7 Restoring the works setting of the internal temperature-probe offset

If the offset has been misadjusted unintentionally, the works setting can be restored with this function.





Command

intern Pt100 extern Pt100	<div style="border: 1px solid black; padding: 5px;">           Calibration <b>Default</b> </div>
<div style="display: flex; justify-content: space-between; width: 100%;"> <span>Help</span> <span>Menu</span> <span>End</span> <span>T<sub>set</sub></span> <span>T<sub>fix</sub></span> </div>	

Confirm input!

Enter key: Continue  
Escape key: Cancel

Help	Menu	End	T <sub>set</sub>	T <sub>fix</sub>
------	------	-----	------------------	------------------

- **Default**
- Open the device parameter menu via the soft key  **Menu** .
- With the cursor keys continue to **→ Settings → Calibration → intern Pt100 → Default** .
- The window shown adjacent appears.
- Confirm selection with  .
- Confirm the control dialog on the right with  or cancel with  .
- Return to the measurement window with **End** or  .

### 7.6.8 Entering the offset of the external temperature probe

If a deviation is found during the check using a calibrated reference thermometer, e.g. from the LAUDA DigiCal Series, then the offset (the additive part of the characteristic) of the external measurement chain can be adjusted with the following function. The reference thermometer must be dipped nearly by the external temperature probe into the consumer bath according to the details on the calibration certificate.



Command		– Calibration
<div style="border: 1px solid black; padding: 5px;">                     intern Pt100                      extern Pt100                 </div>	<div style="border: 1px solid black; padding: 5px;">                     Calibration                      Default                 </div>	<ul style="list-style-type: none"> <li>– Open the device parameter menu via the soft key  Menu .</li> <li>– With the cursor keys continue to → Settings → Calibration → extern Pt100 → Calibration .</li> <li>– The adjacent window appears.</li> <li>– Confirm selection with .</li> <li>– Continue as described in ⇨ 7.6.6 for the internal temperature probe.</li> </ul>
<div style="display: flex; justify-content: space-around; border-top: 1px solid black; border-bottom: 1px solid black;"> <span>Help</span> <span>Menu</span> <span>End</span> <span>T<sub>set</sub></span> <span>T<sub>fix</sub></span> </div>		

### 7.6.9 Restoring the works setting of the external temperature-probe offset

If the offset has been misadjusted unintentionally, the works setting can be restored with this function.

Command		– Default
<div style="border: 1px solid black; padding: 5px;">                     intern Pt100                      extern Pt100                 </div>	<div style="border: 1px solid black; padding: 5px;">                     Calibration                      Default                 </div>	<ul style="list-style-type: none"> <li>– Open the device parameter menu via the soft key  Menu .</li> <li>– With the cursor keys continue to → Settings → Calibration → extern Pt100 → Default .</li> <li>– The adjacent window appears.</li> <li>– Confirm selection with .</li> <li>– Continue as described in 7.6.7 for the internal temperature probe.</li> </ul>
<div style="display: flex; justify-content: space-around; border-top: 1px solid black; border-bottom: 1px solid black;"> <span>Help</span> <span>Menu</span> <span>End</span> <span>T<sub>set</sub></span> <span>T<sub>fix</sub></span> </div>		

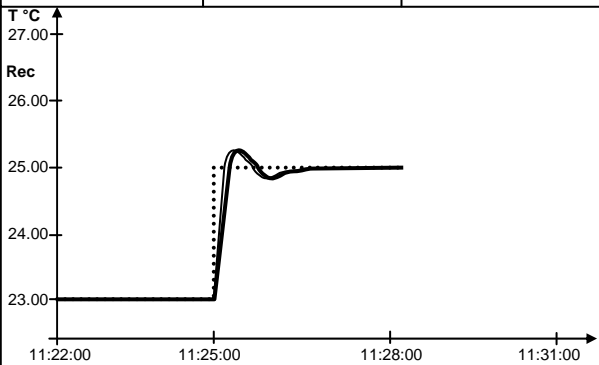
## 7.7 Graphical display of temperature measurements (Command)

Command								
<div style="display: flex; justify-content: space-between; border-bottom: 1px solid black;"> <span>..... T<sub>set</sub>25.00</span> <span>— T<sub>int</sub>25.01</span> <span>— T<sub>ext</sub>25.02</span> </div>  <div style="display: flex; justify-content: space-between; border-top: 1px solid black; border-bottom: 1px solid black;"> <span>Help</span> <span>Menu</span> <span>Screen</span> <span>T<sub>set</sub></span> <span>Graph</span> </div>					<ul style="list-style-type: none"> <li>– <b>Screen</b> and <b>Graph</b></li> <li>– Press the soft key  <b>Screen</b> a number of times as required until the graph recorder window appears.</li> <li>– With the soft key  <b>Graph</b> you enter the menu for the configuration of the graph recorder.</li> <li>– <b>Mode</b> defines,               <ul style="list-style-type: none"> <li>– whether the recording is to run continuously as <b>Online graph</b>,</li> <li>– or whether it is to be started with <b>Start record</b> and later terminated with <b>Stop record</b>. When this start/stop mode is active, <b>Rec</b> flashes at the top left of the display.</li> </ul> </li> <li>– <b>Displayed value</b> defines,               <ul style="list-style-type: none"> <li>– which of the measurements <b>T<sub>int</sub></b>, <b>T<sub>set</sub></b> and/or <b>T<sub>ext</sub></b> is to be graphically displayed. In the menu all combinations are offered.</li> </ul> </li> <li>– <b>Legend</b> defines,               <ul style="list-style-type: none"> <li>– whether the axis label is to be <b>invisible</b> or <b>visible</b>.</li> </ul> </li> <li>– <b>Sample time</b> defines with which time interval the measurements are recorded. 5 possibilities are offered:               <ul style="list-style-type: none"> <li>– From <b>2s (max. 1h45min)</b> up to <b>2min (max. 105h)</b>.</li> <li>– <b>Time axis</b> defines over which time range the measurements are to be displayed.                   <ul style="list-style-type: none"> <li>– With <b>Automatic</b> the program finds the optimum display.</li> <li>– Manual input from <b>9min</b> up to <b>144h</b>.</li> </ul> </li> <li>– <b>Time base</b> defines whether scaling is to be carried out.                   <ul style="list-style-type: none"> <li>– With <b>Relative</b> the start occurs at 00:00:00.</li> <li>– With <b>Absolute</b> the current time is displayed.</li> </ul> </li> </ul> </li> </ul>			
<table border="1" style="width: 100%; border-collapse: collapse;"> <tr> <td style="width: 30%; padding: 5px;"> <b>Mode</b>            Displayed value            Legend            Sample Time            Time axis            Time base            Temp. scale            Temp. limits         </td> <td style="width: 70%; padding: 5px;"> <div style="border: 1px solid black; padding: 5px;"> <b>Online graph</b>            Start Record         </div> </td> </tr> <tr> <td colspan="2" style="display: flex; justify-content: space-between; border-top: 1px solid black; border-bottom: 1px solid black;"> <span>Help</span> <span>Menu</span> <span>End</span> <span>T<sub>set</sub></span> <span>T<sub>fix</sub></span> </td> </tr> </table>					<b>Mode</b> Displayed value Legend Sample Time Time axis Time base Temp. scale Temp. limits	<div style="border: 1px solid black; padding: 5px;"> <b>Online graph</b>            Start Record         </div>	<span>Help</span> <span>Menu</span> <span>End</span> <span>T<sub>set</sub></span> <span>T<sub>fix</sub></span>	
<b>Mode</b> Displayed value Legend Sample Time Time axis Time base Temp. scale Temp. limits	<div style="border: 1px solid black; padding: 5px;"> <b>Online graph</b>            Start Record         </div>							
<span>Help</span> <span>Menu</span> <span>End</span> <span>T<sub>set</sub></span> <span>T<sub>fix</sub></span>								
<table border="1" style="width: 100%; border-collapse: collapse;"> <tr> <td style="width: 30%; padding: 5px;"> <b>Mode</b>            Displayed value            Legend            Sample time            Time axis            Time base            Temp. scale            Temp. limits         </td> <td style="width: 70%; padding: 5px;"> <div style="border: 1px solid black; padding: 5px;"> <b>Tset Tint Text</b>            Tset Tint            Tset Text            Tint Text            Tint            Text            Tset         </div> </td> </tr> <tr> <td colspan="2" style="display: flex; justify-content: space-between; border-top: 1px solid black; border-bottom: 1px solid black;"> <span>Help</span> <span>Menu</span> <span>End</span> <span>T<sub>set</sub></span> <span>T<sub>fix</sub></span> </td> </tr> </table>					<b>Mode</b> Displayed value Legend Sample time Time axis Time base Temp. scale Temp. limits	<div style="border: 1px solid black; padding: 5px;"> <b>Tset Tint Text</b>            Tset Tint            Tset Text            Tint Text            Tint            Text            Tset         </div>	<span>Help</span> <span>Menu</span> <span>End</span> <span>T<sub>set</sub></span> <span>T<sub>fix</sub></span>	
<b>Mode</b> Displayed value Legend Sample time Time axis Time base Temp. scale Temp. limits	<div style="border: 1px solid black; padding: 5px;"> <b>Tset Tint Text</b>            Tset Tint            Tset Text            Tint Text            Tint            Text            Tset         </div>							
<span>Help</span> <span>Menu</span> <span>End</span> <span>T<sub>set</sub></span> <span>T<sub>fix</sub></span>								

Mode Displayed value Legend Sample Time Time axis Time base Temp. scale Temp. limits	Temp. min 22.00 Temp. max 27.00										
<table border="1" style="width: 100%; border-collapse: collapse;"> <tr> <td>Help</td> <td>Menu</td> <td>End</td> <td>T<sub>set</sub></td> <td>T<sub>fix</sub></td> </tr> </table>	Help	Menu	End	T <sub>set</sub>	T <sub>fix</sub>						
Help	Menu	End	T <sub>set</sub>	T <sub>fix</sub>							
<div style="border: 1px solid black; padding: 10px; width: fit-content; margin: 0 auto;">                 y-axis Limit:   <div style="font-size: 2em; font-weight: bold; text-align: center; margin: 10px 0;">22.00</div> <hr style="width: 20%; margin: 0 auto;"/>                 Min: -150.00°C    Max: 26.90 °C             </div>											
<table border="1" style="width: 100%; border-collapse: collapse;"> <tr> <td style="width: 20%;">1</td> <td style="width: 20%;">2</td> <td style="width: 20%;">3</td> <td style="width: 20%;">4</td> <td style="width: 20%;">5</td> </tr> <tr> <td>6</td> <td>7</td> <td>8</td> <td>9</td> <td>0</td> </tr> </table>		1	2	3	4	5	6	7	8	9	0
1	2	3	4	5							
6	7	8	9	0							

- **Temp. scale** defines how the scaling is to be carried out:
- **automatic**, by the program, **or**
- **manual** in that you yourself define the limits with the next menu point.
- The min. and max. values for the graphical display are manually entered with **Temp. limits**.
- **Temp. min 22.00°C** is the momentary minimum value.
- **Temp. max 27.00°C** is the momentary maximum value.
- The highlighted value can in each case be changed with . Enter the desired new value in the changes window in the usual way.
- When setting the minimum value, the largest permissible value (here 26.90 °C, since the maximum value is 27 °C) is stated.
- When setting the maximum value, it is conversely the minimum value, which is entered.
- However, if a value is entered which exceeds the other corresponding limit, then this warning is issued:  

Warning: Value not in input range

 .

### 7.8 Programmer (PGM only Command)

Almost any temperature/time profile can be created with the programmer. A desired bath temperature can be approached as quickly as possible or via a defined ramp. Furthermore, the pump level and the behavior of the switching outputs can be defined. Five temperature/time programs are provided for free programming. Each program consists of a number of temperature/time segments. Also included are details of how often the program is to be executed (loops). The sum of all segments of all programs may be up to a maximum of 150. A warning is given if the creation of more than 150 segments is attempted.

Typical segments are:

**Ramp:** If a time is specified, then the segment is a ramp, which is described by the target temperature, i.e. the temperature at the end of the segment, and the duration from the start to the end of the segment.

**Step:** Without any specified time the final temperature is approached as quickly as possible.

**Temperature hold phase:** No temperature change (i.e. the temperatures at the start and end of a segment are the same).



The programmer can be controlled or changed via the RS 232 interface, the timer or switching contacts.

#### 7.8.1 Program example

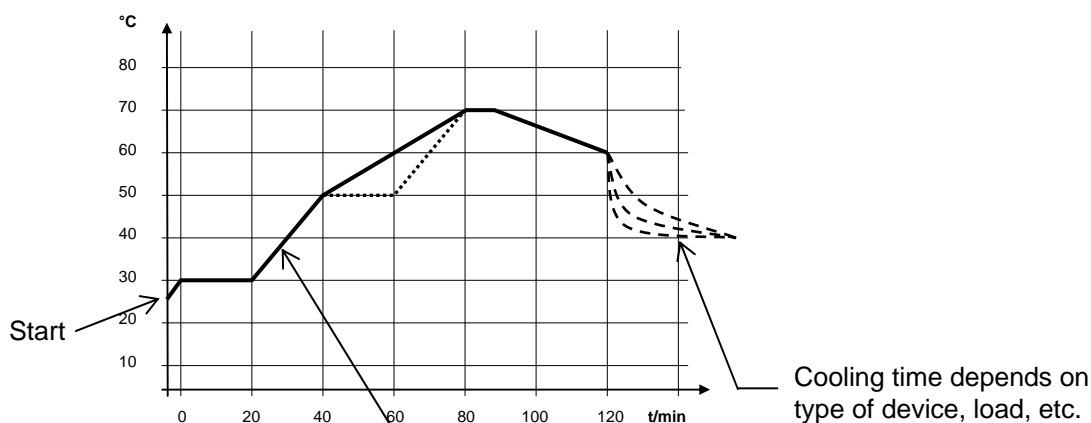

Real program example with 6 segments

No	T end °C	Time [h:m]	Tolerance	No	Pump	Out 1	Out 2	Out 3	
Start	30.00°C	-----	0.00°C	Start	-----	-----	-----	-----	
1	30.00°C	00:20	0.10°C	1	2	-----	-----	-----	
2	50.00°C	00:20	0.00°C	2	3	-----	-----	-----	
3	70.00°C	00:40	0.00°C	3	4	-----	-----	-----	
4	70.00°C	00:10	0.10°C	4	2	-----	-----	-----	
5	60.00°C	00:30	0.00°C	5	2	-----	-----	-----	
6	30.00°C	00:00	0.00°C	6	2	-----	-----	-----	
Help	Menu	End	Insert	Delete	Help	Menu	End	Insert	Delete



Each program begins with the segment "Start". It defines at which temperature Segment 1 is to continue the program. It is not possible to specify a time for the Start segment. For thermostats without cooling ability, the start temperature must be selected higher than the bath temperature, which prevails before the program start. Without the Start segment, Segment 1 would be different depending on the bath temperature at the start of the program.

**Edited program example (see dashed curve in the graph on previous page).**

No	T end °C	Time [h:m]	Tolerance				
Start	30.00°C	-----	0.00°C				
1	30.00°C	00:20	0.10°C				
2	50.00°C	00:20	<b>0.00°C</b> ③				
3①	<b>50.00°C</b> ①	<b>00:20</b> ②	0.10°C ③				
4	70.00°C	<b>00:20</b> ②	0.00°C				
5	70.00°C	00:10	<b>0.80°C</b> ③				
6	60.00°C	00:30	0.00°C				
7	30.00°C	00:00	0.00°C				
<table border="1" style="width:100%; border-collapse: collapse;"> <tr> <td style="width:25%;">Help</td> <td style="width:25%;">Menu</td> <td style="width:25%;">End</td> <td style="width:25%;">Delete</td> </tr> </table>				Help	Menu	End	Delete
Help	Menu	End	Delete				

No	Pump	Out 1	Out 2	Out 3					
Start	-----	-----	-----	-----					
1	2	-----	-----	-----					
2	2	-----	-----	-----					
3	2	-----	-----	-----					
4	2	-----	-----	-----					
5	2	-----	-----	-----					
6	2	-----	-----	-----					
7	2	-----	-----	-----					
<table border="1" style="width:100%; border-collapse: collapse;"> <tr> <td style="width:20%;">Help</td> <td style="width:20%;">Menu</td> <td style="width:20%;">End</td> <td style="width:20%;">Insert</td> <td style="width:20%;">Delete</td> </tr> </table>					Help	Menu	End	Insert	Delete
Help	Menu	End	Insert	Delete					

① Insert new segment (⇒ Section 7.8.4)

② ③ Change segment time or tolerance (⇒ Section 7.8.4)



**The field tolerance** (refer to the above program table and the graph below):

- It facilitates exact conformance to the dwell time at a specified temperature. Segment 1 is not processed until the bath temperature is within the tolerance range ①, so that the ramp (Segment 2) starts delayed at ②.
- A tolerance range which is too tight can however also cause undesired delays. **In particular with external control** the range should not be chosen too tightly. In Segment 5 a larger tolerance has been entered, so that the desired time of ten minutes is maintained even with settling action ③.
- Only flat (slow) ramps should be programmed where necessary with a tolerance range. Steep ramps which lie close to the maximum possible heating or cooling rates of the thermostat may be severely delayed by a tolerance range that is too tight (here in Segment 2) ④.

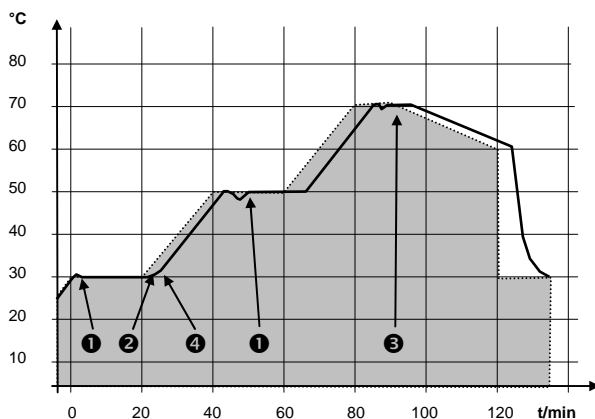

Example for the influence of the tolerance field input in case of external bath temperature control:



The setpoint temperature of the programmer is shown in grey.

The actual temperature in the external bath container is represented as a continuous line.

## 7.8.2 Selecting and starting the program (Start, Hold, Stop)

Here you will learn how to select and start a program that has already been created. If no program has been created ⇒ 7.8.4 “Creating or modifying a program (Edit)”.

<b>Programmer</b> <b>Program 1</b>																
Pump Settings Graph Clock Programmer Interfaces Control Limits	<table border="1" style="width: 100%; border-collapse: collapse;"> <tr> <td style="padding: 5px;">Program 1</td> </tr> <tr> <td style="padding: 5px;">Program 2</td> </tr> <tr> <td style="padding: 5px;">Program 3</td> </tr> <tr> <td style="padding: 5px;">Program 4</td> </tr> <tr> <td style="padding: 5px;">Program 5</td> </tr> <tr> <td style="padding: 5px;">Ramp function</td> </tr> </table>				Program 1	Program 2	Program 3	Program 4	Program 5	Ramp function						
Program 1																
Program 2																
Program 3																
Program 4																
Program 5																
Ramp function																
Help	Menu	End	T <sub>set</sub>	T <sub>fix</sub>												
<table border="1" style="width: 100%; border-collapse: collapse;"> <tr> <td style="width: 20%; padding: 5px; vertical-align: top;">                     Status                      Edit                      Loops                      Graph                      Info                 </td> <td colspan="4" style="padding: 5px; vertical-align: top;"> <table border="1" style="width: 100%; border-collapse: collapse;"> <tr> <td style="padding: 5px;">Start</td> </tr> </table> </td> </tr> <tr> <td style="padding: 5px; text-align: center;">Help</td> <td style="padding: 5px; text-align: center;">Menu</td> <td style="padding: 5px; text-align: center;">End</td> <td style="padding: 5px; text-align: center;">T<sub>set</sub></td> <td style="padding: 5px; text-align: center;">T<sub>fix</sub></td> </tr> </table>					Status Edit Loops Graph Info	<table border="1" style="width: 100%; border-collapse: collapse;"> <tr> <td style="padding: 5px;">Start</td> </tr> </table>				Start	Help	Menu	End	T <sub>set</sub>	T <sub>fix</sub>	
Status Edit Loops Graph Info	<table border="1" style="width: 100%; border-collapse: collapse;"> <tr> <td style="padding: 5px;">Start</td> </tr> </table>				Start											
Start																
Help	Menu	End	T <sub>set</sub>	T <sub>fix</sub>												
<table border="1" style="width: 100%; border-collapse: collapse;"> <tr> <td style="width: 20%; padding: 5px; vertical-align: top;">                     Status                      Edit                      Loops                      Graph                      Info                 </td> <td colspan="4" style="padding: 5px; vertical-align: top;"> <table border="1" style="width: 100%; border-collapse: collapse;"> <tr> <td style="padding: 5px;">Hold</td> </tr> <tr> <td style="padding: 5px;">Stop</td> </tr> </table> </td> </tr> <tr> <td style="padding: 5px; text-align: center;">Help</td> <td style="padding: 5px; text-align: center;">Menu</td> <td style="padding: 5px; text-align: center;">End</td> <td colspan="2" style="padding: 5px; text-align: center;"><b>Prog.1 running</b></td> </tr> </table>					Status Edit Loops Graph Info	<table border="1" style="width: 100%; border-collapse: collapse;"> <tr> <td style="padding: 5px;">Hold</td> </tr> <tr> <td style="padding: 5px;">Stop</td> </tr> </table>				Hold	Stop	Help	Menu	End	<b>Prog.1 running</b>	
Status Edit Loops Graph Info	<table border="1" style="width: 100%; border-collapse: collapse;"> <tr> <td style="padding: 5px;">Hold</td> </tr> <tr> <td style="padding: 5px;">Stop</td> </tr> </table>				Hold	Stop										
Hold																
Stop																
Help	Menu	End	<b>Prog.1 running</b>													

- **Programmer** **Program 1**
- Open the device parameter menu via the soft key  **Menu**.
- With the cursor keys continue to: → **Programmer** → **Program 1**.
- Confirm with the key .

- The submenu **Status** appears.
- Using the **Status** menu, the selected program can be:
  1. started **Start**,
  2. paused **Hold**,
  3. continued **Continue** or
  4. terminated **Stop**.

In addition, the standby key  stops the programmer! (Pause operation). After standby is deactivated, the programmer goes on! Commands, which, depending on the situation, cannot be executed, are not displayed. **Continue** therefore only appears when **Hold** has been activated.

- Once the start has been confirmed with , **Prog. 1 running** appears at the bottom.

**7.8.3 Interrupting, continuing or terminating the program (Hold, Continue, Stop)**

Command	<span style="border: 1px solid black; padding: 2px;">Programmer</span> <span style="border: 1px solid black; padding: 2px;">Program 1</span> <span style="border: 1px solid black; padding: 2px;">Status</span>														
<div style="border: 1px solid black; padding: 5px;"> <table style="width: 100%; border-collapse: collapse;"> <tr> <td style="border: 1px solid black; padding: 2px;">Status</td> <td style="border: 1px solid black; padding: 2px;"><b>Hold</b></td> </tr> <tr> <td style="border: 1px solid black; padding: 2px;">Edit</td> <td style="border: 1px solid black; padding: 2px;">Stop</td> </tr> <tr> <td style="border: 1px solid black; padding: 2px;">Loops</td> <td></td> </tr> <tr> <td style="border: 1px solid black; padding: 2px;">Graph</td> <td></td> </tr> <tr> <td style="border: 1px solid black; padding: 2px;">Info</td> <td></td> </tr> </table> </div> <div style="border: 1px solid black; padding: 5px; margin-top: 5px;"> <table style="width: 100%; border-collapse: collapse;"> <tr> <td style="border: 1px solid black; padding: 2px;">Help</td> <td style="border: 1px solid black; padding: 2px;">Menu</td> <td style="border: 1px solid black; padding: 2px;">End</td> <td style="border: 1px solid black; padding: 2px;"><b>Prog.1running</b></td> </tr> </table> </div>	Status	<b>Hold</b>	Edit	Stop	Loops		Graph		Info		Help	Menu	End	<b>Prog.1running</b>	<ul style="list-style-type: none"> <li>- After a program has been started by pressing the  key, the command options <b>Hold</b> or <b>Stop</b> are shown.</li> <li>- Here, with the aid of the keys  or  and  the running program can be paused with <b>Hold</b> or terminated with <b>Stop</b>.</li> <li>- Once the program has been terminated, the device runs with the last setpoint setting.</li> </ul>
Status	<b>Hold</b>														
Edit	Stop														
Loops															
Graph															
Info															
Help	Menu	End	<b>Prog.1running</b>												
<div style="border: 1px solid black; padding: 5px;"> <table style="width: 100%; border-collapse: collapse;"> <tr> <td style="border: 1px solid black; padding: 2px;">Status</td> <td style="border: 1px solid black; padding: 2px;"><b>Continue</b></td> </tr> <tr> <td style="border: 1px solid black; padding: 2px;">Edit</td> <td style="border: 1px solid black; padding: 2px;">Stop</td> </tr> <tr> <td style="border: 1px solid black; padding: 2px;">Loops</td> <td></td> </tr> <tr> <td style="border: 1px solid black; padding: 2px;">Graph</td> <td></td> </tr> <tr> <td style="border: 1px solid black; padding: 2px;">Info</td> <td></td> </tr> </table> </div> <div style="border: 1px solid black; padding: 5px; margin-top: 5px;"> <table style="width: 100%; border-collapse: collapse;"> <tr> <td style="border: 1px solid black; padding: 2px;">Help</td> <td style="border: 1px solid black; padding: 2px;">Menu</td> <td style="border: 1px solid black; padding: 2px;">End</td> <td style="border: 1px solid black; padding: 2px;"><b>Prog.1Standby</b></td> </tr> </table> </div>	Status	<b>Continue</b>	Edit	Stop	Loops		Graph		Info		Help	Menu	End	<b>Prog.1Standby</b>	<ul style="list-style-type: none"> <li>- Continuation of a program paused with <b>Hold</b> occurs using <b>Continue</b> which is obtained with .</li> </ul>
Status	<b>Continue</b>														
Edit	Stop														
Loops															
Graph															
Info															
Help	Menu	End	<b>Prog.1Standby</b>												
<div style="border: 1px solid black; padding: 5px;"> <table style="width: 100%; border-collapse: collapse;"> <tr> <td style="border: 1px solid black; padding: 2px;">Status</td> <td style="border: 1px solid black; padding: 2px;"><b>Continue</b></td> </tr> <tr> <td style="border: 1px solid black; padding: 2px;">Edit</td> <td style="border: 1px solid black; padding: 2px;">Stop</td> </tr> <tr> <td style="border: 1px solid black; padding: 2px;">Loops</td> <td></td> </tr> <tr> <td style="border: 1px solid black; padding: 2px;">Graph</td> <td></td> </tr> <tr> <td style="border: 1px solid black; padding: 2px;">Info</td> <td></td> </tr> </table> </div> <div style="border: 1px solid black; padding: 5px; margin-top: 5px;"> <table style="width: 100%; border-collapse: collapse;"> <tr> <td style="border: 1px solid black; padding: 2px;">Help</td> <td style="border: 1px solid black; padding: 2px;">Menu</td> <td style="border: 1px solid black; padding: 2px;">End</td> <td style="border: 1px solid black; padding: 2px;"><b>Pr. 1 Standby</b></td> </tr> </table> </div>	Status	<b>Continue</b>	Edit	Stop	Loops		Graph		Info		Help	Menu	End	<b>Pr. 1 Standby</b>	<ul style="list-style-type: none"> <li>- In addition, the standby key  stops the programmer. The pump, heater and cooling unit are switched off. Follow the safety information ⇨ 7.5.3.</li> <li>- After pressing the standby key  again, the programmer returns to the previously selected operating mode: Pause or active operation depending on what was previously selected.</li> </ul>
Status	<b>Continue</b>														
Edit	Stop														
Loops															
Graph															
Info															
Help	Menu	End	<b>Pr. 1 Standby</b>												

## 7.8.4 Creating or modifying a program (Edit)

Here, there are the following functions:

- Entry of a program.
- Display of the program data of a saved program and modification of the segment data.
- Insertion or appending of a new segment.
- Deletion of a segment.



- In addition, when a program has just been executed, new segments can be inserted and existing ones modified, even the currently active segment. Furthermore, all segments, except the currently active one, can be deleted at any time.
- Modifications to the currently running segment are possible. The segment then continues as though the modification had been applicable since the start of the segment.

**However:** If the new segment time is shorter than the segment time that has already run, then the program skips to the next segment.

- If a segment time >999h: 59min is required, then this time period must be shared over a number of consecutive segments.

### Entering a program:

Program example (⇒ 7.8.1)

<b>Command</b>					<ul style="list-style-type: none"> <li>- Programmer Program1 Edit</li> <li>Modify</li> </ul>		
Status <input style="width: 100px;" type="text" value="Edit"/> Loops Graph Info	<table border="1" style="width: 100%; border-collapse: collapse;"> <tr> <td style="padding: 5px;">Modify</td> <td style="padding: 5px;">Delete</td> </tr> </table>				Modify	Delete	<ul style="list-style-type: none"> <li>- In the Edit menu one can Modify or Delete a program.</li> <li>- Press the  key.</li> <li>- Continue to Modify with the key .</li> <li>- There is the possibility of modifying single segments, i.e. segments can be entered as new, changed and also deleted.</li> </ul>
Modify	Delete						
Help	Menu	End	T <sub>set</sub>	T <sub>fix</sub>			

No.	T end °C	Time [h:m]	Tolerance	
Start	30.00°C	-----	3.00°C	
1	30.00°C	00:30	3.00°C	
Help	Menu	End	Insert	Delete

- In the "Start" line enter in the field "T end °C" the temperature at which the sequence is to start (default value is 30 °C). A time entry is not possible in the "Start" segment, because the thermostat immediately executes Segment 1 on reaching the start temperature.
- Delete single segments (rows) with **Delete**.
- For thermostats without cooling ability, the setpoint temperature must be obtainable, i.e. above the bath temperature displayed at the time of the program start.

- Using the cursor keys move the black background to the field, which you would like to change. It can be edited by pressing the key  (see following pages).

- The soft key  **Insert** inserts in the marked line a new segment that has a default value taken from the previous segment with the exception of the Tolerance field. The Tolerance is always specified as 0.00. All following segment lines will be moved one line downwards.

- In the above window Segment 1 was created in this way.

- Continue with  to the fields ⇒ "Time" ⇒ "Tolerance". See program example in 7.8.1.

- If there is no entry in the "Time" field, the bath temperature is approached as quickly as possible. With a time entry the final temperature is obtained exactly after the time expires (ramp).

- The entry in the field "Tolerance" field defines how accurately the final temperature is to be obtained before the next segment is processed.

 If the tolerance range has been selected too small, it may be that the program does not continue, because the required tolerance is never achieved.

External temperature control: Especially with ramps, a too close tolerance range can cause undesired delays in the start phase of the ramp.

No.	Pump	Out 1	Out 2	Out 3
Start	-----	-----	-----	-----
1	4	-----	-----	-----
Help	Menu	End	Insert	Delete

- Then continue with  to the pump and signal output setting.
- The right-hand part of the entry table appears as shown on the left.
- Here, in the "Pump" field, the pump level and, in the fields "Out 1" to "Out 3", the contact outputs of the contact mode (accessory) can be programmed. With the setting "-----" the starting value is retained which was either set before the program start or was defined by a previous segment in the running program. Further details are given on the following pages.

End of segment temperature:

25.00

Min: -150.00°C Max:450.00°C

1	2	3	4	5
6	7	8	9	0

Input segment time:

003:00

Hours(max.999):Minutes











1	2	3	4	5
6	7	8	9	0

Temp. tolerance (0=off):

10.00

Min: 0.00°C Max:450.00°C

6	7	8	9	0

- A new segment is produced by moving the cell with the black background to a blank line with the cursor keys and then pressing the soft key  **Insert** . The values of the cell located above it are automatically copied.
- If the field in the column **T end °C** has a black background, the entry mode "End of segment temperature" is obtained by pressing the  key. Depending on the setting, that is the temperature, which the thermostat is to achieve on the internal or external temperature probe.
- Enter the value, confirm with the  key and continue to the "Time" entry field with .
- If the field in the column **Time** " has a black background, the entry mode for the "Segment time" time setting is obtained by pressing the  key.
- If 0 is entered into the field "Time", "-----" appears. Then the final temperature is approached as quickly as possible. With a time entry the final temperature is obtained exactly after the time expires (ramp).
- Enter the segment time and confirm with the  key.
- Continue to the "Tolerance" entry field with .
- If the field in the column "Tolerance" has a black background, the entry mode for the "Temperature tolerance" is obtained by pressing the  key. It defines how accurately the end of segment temperature is to be obtained before the next segment is processed. A tolerance which is selected too small can stop the next segment from being started according to plan.
- Set the temperature tolerance and confirm with .
- Continue with  to the entry field "Pump".











Pump level	Level 8 Level 7 Level 6 <b>Level 5</b> Level 4 Level 3 Level 2 Level 1 -----
------------	--

Help	Menu	End	T <sub>set</sub>	T <sub>fix</sub>
------	------	-----	------------------	------------------

Contact out	----- open closed
-------------	-------------------------

Help	Menu	End	T <sub>set</sub>	T <sub>fix</sub>
------	------	-----	------------------	------------------

- If the field in the column "Pump" has a black background, the entry mode for the **Pump level** is obtained by pressing the key .
- With  or  select Pump Level 5 – 8 or "-----" and confirm with . "-----" stands for "no change to previous segment", i.e. when "-----" is present in all fields, the pump level always retains the start setting or the setting before the program start.
- Continue with  to the field "Out 1", "Out 2" or "Out 3".
- The contact outputs of the contact module (if present, special accessory) are programmed here.
- If the field in the column "Out 1" has a black background, the entry mode for the **Contact output** is obtained by pressing the  key.
- With  or  select -----, **Open** or **Closed** and confirm with . ----- stands for no change with respect to the previous segment, i.e. if ----- is present in all fields, the contact setting of the start setting or that from the program start is retained.
- If applicable, continue with  to "Out 2" and "Out 3".
- Programming is terminated with  or **End**.

## 7.8.5 Defining the number of program loops (Loops)

<span style="background-color: black; color: white; padding: 2px;">Programmer</span> <span style="background-color: black; color: white; padding: 2px;">Program1</span> <span style="background-color: black; color: white; padding: 2px;">Loops</span>														
Status Edit <span style="border: 1px solid black; padding: 2px;">Loops</span> Graph Info	<div style="border: 2px solid black; padding: 10px; width: fit-content; margin: 0 auto;"> <span style="font-size: 24px; font-weight: bold;">1</span> </div>													
<span>Help</span> <span>Menu</span> <span>End</span> <span>T<sub>set</sub></span> <span>T<sub>fix</sub></span>														
<div style="border: 2px solid black; padding: 10px; width: fit-content; margin: 0 auto;">                 Loops (0=infinite)   <span style="font-size: 48px; font-weight: bold; margin: 0 auto;">1</span>  <hr style="width: 50%; margin: 0 auto;"/>                 Min: 0                      Max:255             </div>														
<table border="1" style="margin: 0 auto; border-collapse: collapse;"> <tr> <td style="width: 20px; text-align: center;">1</td> <td style="width: 20px; text-align: center;">2</td> <td style="width: 20px; text-align: center;">3</td> <td style="width: 20px; text-align: center;">4</td> <td style="width: 20px; text-align: center;">5</td> </tr> <tr> <td style="text-align: center;">6</td> <td style="text-align: center;">7</td> <td style="text-align: center;">8</td> <td style="text-align: center;">9</td> <td style="text-align: center;">0</td> </tr> </table>					1	2	3	4	5	6	7	8	9	0
1	2	3	4	5										
6	7	8	9	0										

- If required, programs can be looped many times.
- With and access the menu Loops.
- Select the number of desired program loops.
- Press the key, set the required number. Entering 0 causes the program to repeat continuously.
- Confirm the entry with the key and return to the display.
- You can quit the Edit mode with or End.

## 7.8.6 Viewing the program sequence as a graph (Graph)

<span style="background-color: black; color: white; padding: 2px;">Programmer</span> <span style="background-color: black; color: white; padding: 2px;">Program1</span> <span style="background-color: black; color: white; padding: 2px;">Graph</span>				
Status Edit Loops <span style="border: 1px solid black; padding: 2px;">Graph</span> Info	<div style="border: 2px solid black; padding: 10px; width: fit-content; margin: 0 auto;"> <span style="font-size: 24px; font-weight: bold;">Show chart</span> </div>			
<span>Help</span> <span>Menu</span> <span>End</span> <span>T<sub>set</sub></span> <span>T<sub>fix</sub></span>				

- takes you to the submenu Graph.
- Press the key ⇨ Show chart and .
- The program sequence is shown.

Help	Menu	End	T <sub>set</sub>	T <sub>fix</sub>
------	------	-----	------------------	------------------

- The display of the programmed temperature curve can be quit with or **End** .

**7.8.7 Obtaining information on a program (Info)**

**Command**

Status Edit Loops Graph Info	<table border="1" style="width: 100%; border-collapse: collapse;"> <tr> <td style="background-color: #333; color: white; padding: 2px;"><b>Segments</b></td> <td style="text-align: right; padding: 2px;"><b>2</b></td> </tr> <tr> <td style="padding: 2px;">Temp.min</td> <td style="text-align: right; padding: 2px;">20.00°C</td> </tr> <tr> <td style="padding: 2px;">Temp.max</td> <td style="text-align: right; padding: 2px;">40.00°C</td> </tr> <tr> <td style="padding: 2px;">Duration</td> <td style="text-align: right; padding: 2px;">01:00</td> </tr> <tr> <td style="padding: 2px;">Seg. free</td> <td style="text-align: right; padding: 2px;">145</td> </tr> <tr> <td style="padding: 2px;">Actual Seg.</td> <td style="text-align: right; padding: 2px;">5</td> </tr> <tr> <td style="padding: 2px;">Seg. Remain</td> <td style="text-align: right; padding: 2px;">00:05</td> </tr> <tr> <td style="padding: 2px;">Loop actual</td> <td style="text-align: right; padding: 2px;">3</td> </tr> </table>	<b>Segments</b>	<b>2</b>	Temp.min	20.00°C	Temp.max	40.00°C	Duration	01:00	Seg. free	145	Actual Seg.	5	Seg. Remain	00:05	Loop actual	3
<b>Segments</b>	<b>2</b>																
Temp.min	20.00°C																
Temp.max	40.00°C																
Duration	01:00																
Seg. free	145																
Actual Seg.	5																
Seg. Remain	00:05																
Loop actual	3																

Help	Menu	End	Prog.1	Standby
------	------	-----	--------	---------

- **Programmer** **Program1** **Info**
- Continue with to **Info** .
- Here, all information is displayed about the entered program sequence.
- Number of segments.
- Minimum temperature in °C.
- Maximum temperature in °C.
- Program duration in hh: mm (without the time, which is necessary to process step changes in temperature).
- Number of free segments.
- Segment, which is at present (currently) being processed.
- Residual time of the current segment in hours and minutes.
- Current pass; in the example the third of all passes is running.

The last three points are only displayed when a program runs.

- Quit the window with or **End** .

## 7.9 Ramp function



With the ramp function, temperature changes over any time period can be conveniently entered. This is especially advantageous with very low temperature changes (e.g. 0.1 °C/ day).

Example: From the current outflow temperature (e.g. 242.4 °C) 200 °C of cooling is to occur over 5 days.

Then 200 °C is entered as the temperature change, the time value 5 is entered for the time and day(s) selected as the time unit.



The ramp function is executed until it is manually terminated or until the temperature limits  $T_{il}$  (min) or  $T_{ih}$  (max) described in Section 7.6.2 are attained.

Command		– Ramp function	
Pump Settings Graph Clock Programmer Interfaces Control Limits	Program 1 Program 2 Program 3 Program 4 Program 5 <b>Ramp function</b>	–	Open the list of device parameters using the soft key  <b>Menu</b> .
		–	With the cursor keys continue to → <b>Programmer</b> → <b>Ramp function</b> .
		–	Confirm with the key  .
Help   Menu   End   $T_{set}$   $T_{fix}$			
Status Temp. change Time Time unit	Second(s) Minute(s) Hour(s) <b>Day(s)</b>	–	Enter a positive or negative temperature value with <b>Temp. change</b> .
		–	With <b>Time</b> enter a figure (without time unit).
		–	With <b>Time unit</b> choose between <b>Second(s)</b> up to <b>Day(s)</b> .
		–	Under <b>Status</b> the ramp is started → <b>Start</b> or stopped → <b>Stop</b> .
		–	When the ramp function is being executed, <b>Ramp active</b> appears in the window bar.
		–	Without manual switch-off the ramp terminates at the latest at $T_{il}$ (min) or $T_{ih}$ (max).
Help   Menu   End   $T_{set}$   $T_{fix}$			

### 7.10 Timer function (Command)

Using the timer function, the thermostat can carry out an action at a certain time or after a certain waiting period. The actions are: switching on the thermostat, entering the standby mode or one of the 5 programs in the programmer.

<div style="border: 1px solid black; padding: 5px;"> <p><b>Command</b></p> <table style="width: 100%; border-collapse: collapse;"> <tr> <td style="width: 50%; border-right: 1px solid black; padding: 5px;">                 Pump Settings Graph <b>Clock</b> Programmer Interfaces Control Limits             </td> <td style="width: 50%; padding: 5px;">                 Set time Set date <b>Timer 1</b> Timer 2 Format of date             </td> </tr> </table> <table style="width: 100%; border-collapse: collapse; margin-top: 5px;"> <tr> <td style="border: 1px solid black; padding: 2px 5px;">Help</td> <td style="border: 1px solid black; padding: 2px 5px;">Menu</td> <td style="border: 1px solid black; padding: 2px 5px;">End</td> <td style="border: 1px solid black; padding: 2px 5px;">T<sub>set</sub></td> <td style="border: 1px solid black; padding: 2px 5px;">T<sub>fix</sub></td> </tr> </table> </div>	Pump Settings Graph <b>Clock</b> Programmer Interfaces Control Limits	Set time Set date <b>Timer 1</b> Timer 2 Format of date	Help	Menu	End	T <sub>set</sub>	T <sub>fix</sub>	<ul style="list-style-type: none"> <li>- <b>Clock</b> <b>Timer 1</b> <b>Timer 2</b></li> <li>- Open the device parameter menu via the soft key  <b>Menu</b> .</li> <li>- With the cursor keys continue to: → <b>Clock</b> → <b>Timer 1</b> ,</li> <li>- or to <b>Timer 2</b> ,</li> <li>- with the menu <b>Status</b> the selected timer is switched <b>off</b> or <b>on</b> .</li> <li>- The standby key  does not stop the timer!</li> </ul>
Pump Settings Graph <b>Clock</b> Programmer Interfaces Control Limits	Set time Set date <b>Timer 1</b> Timer 2 Format of date							
Help	Menu	End	T <sub>set</sub>	T <sub>fix</sub>				
Please exercise caution when thermostat is in standby mode. (⇒ 7.5.3) A previously activated timer mode could unintentionally start the thermostat again from the standby mode.								
<div style="border: 1px solid black; padding: 5px;"> <table style="width: 100%; border-collapse: collapse;"> <tr> <td style="width: 50%; border-right: 1px solid black; padding: 5px;">                 Status <b>Function</b> Action Set Time Set Date             </td> <td style="width: 50%; padding: 5px;">                 Weekplan <b>Time absolute</b> Time relative             </td> </tr> </table> <table style="width: 100%; border-collapse: collapse; margin-top: 5px;"> <tr> <td style="border: 1px solid black; padding: 2px 5px;">Help</td> <td style="border: 1px solid black; padding: 2px 5px;">Menu</td> <td style="border: 1px solid black; padding: 2px 5px;">End</td> <td style="border: 1px solid black; padding: 2px 5px;">T<sub>set</sub></td> <td style="border: 1px solid black; padding: 2px 5px;">T<sub>fix</sub></td> </tr> </table> </div>	Status <b>Function</b> Action Set Time Set Date	Weekplan <b>Time absolute</b> Time relative	Help	Menu	End	T <sub>set</sub>	T <sub>fix</sub>	<ul style="list-style-type: none"> <li>- The menu <b>Function</b> is used to define <b>when</b> an action is executed:</li> <li>- Similar to an electronic mains timer, <b>Weekplan</b> enables two switching events to be carried out each day. The cycle is repeated after 7 days.</li> <li>- <b>Time absolute</b> defines a time and a date on which a once-only action (switching event) occurs. The time point is set with <b>Set time</b> and with <b>Set date</b> .</li> <li>- <b>Time relative</b> defines a waiting period after which a once-only action occurs. With <b>Set time</b> up to 99h: 59min can be entered. ("Set date" is masked out with this function selection).</li> <li>- If the <b>Weekplan</b> is activated, in this window only <b>Status</b> , <b>Function</b> and <b>Weekplan</b> are displayed.</li> </ul>
Status <b>Function</b> Action Set Time Set Date	Weekplan <b>Time absolute</b> Time relative							
Help	Menu	End	T <sub>set</sub>	T <sub>fix</sub>				

Weekplan				
	Time	Action	Time	Action
Monday	07:30	Start	17:00	-----
Tuesday	10:00	Prog.4	17:00	-----
Wednesday	08:00	-----	17:00	-----
Thursday	08:00	-----	17:00	-----
Friday	08:00	-----	16:00	Standby
Saturday	08:00	-----	17:00	-----
Sunday	08:00	-----	17:00	-----
Help	Menu	End	T <sub>set</sub>	T <sub>fix</sub>

Status Function Action Set time Set date	<div style="border: 1px solid black; padding: 5px;"> <b>Start</b>            Standby            Program 1            Program 2            Program 3            Program 4            Program 5         </div>			
Help	Menu	End	T <sub>set</sub>	T <sub>fix</sub>

- **Weekplan** → **Arrange** takes you to the window shown on the left.
- Using the cursor keys and select the field, which is to be filled in.
- Open the input dialog of the field with : Select a time in the time fields and an action in the action field.
- In the example on the right, the thermostat is started on Monday at 7:30h, Program 4 is executed at 10:00h on Tuesday and the standby mode is switched in on Friday at 16:00h. Fields displaying ----- are passive.
- Confirm each field selection with or quit with without making changes.

The menu **Action** is used to define **what** is to be carried out:

- **Start** activates the thermostat from the standby mode.
- **Standby** activates the standby mode (refrigerating unit, heater and pump are switched off).
- **Program X** all actions of this program defined in the programmer are processed.

## 7.11 Control parameters

The control parameters are optimized ex-works for operation as a bath thermostat (with water as the bath medium) with internal control. The parameters are also preset for the operation of external containers with external control. Sometimes however, the operation of external containers requires adaptation. In addition, the thermal capacity and viscosity of the heat transfer liquid sometimes require adaptation.



- The intelligent menu guidance with the Master and Command control elements detects whether you have set the device (as described in Section 7.5.4), to internal or external control and only displays, the relevant dialog boxes in each case.
- Your Proline Kryomat automatically optimizes some control parameters. This automatic mechanism should only be deactivated and manually optimized in exceptional cases.

**7.11.1 Internal control variable (integral measurement probe)**

Only read further here, if you have no external temperature probe connected (and activated according to Section 7.5.4 as control variable).

<div style="border: 1px solid black; padding: 5px;"> <p><b>Command</b></p> <div style="display: flex; justify-content: space-between; align-items: flex-start;"> <div style="border: 1px solid black; padding: 2px;">Control Parameters</div> <table style="border: 1px solid black; text-align: right;"> <tr><td style="border: none;">Xp</td><td style="border: none;">6,0</td></tr> <tr><td style="border: none;">Tn</td><td style="border: none;">30</td></tr> <tr><td style="border: none;">Tv (auto)</td><td style="border: none;">21</td></tr> <tr><td style="border: none;">Td (auto)</td><td style="border: none;">3,5</td></tr> </table> </div> </div>	Xp	6,0	Tn	30	Tv (auto)	21	Td (auto)	3,5	<ul style="list-style-type: none"> <li>- <b>Control Parameters</b></li> <li>- Open the device parameter menu via the soft key  <b>Menu</b> .</li> <li>- With the cursor keys continue to <b>→ Control → Control Parameters → Control Parameters</b> .</li> <li>- The adjacent window appears.</li> <li>- Change parameters marked with (auto) where necessary to manual input with <b>Tv manual/auto</b> .</li> <li>- Select the parameters to be changed with  and confirm with  .</li> <li>- Then in the following settings window, change the value and confirm with  .</li> </ul>
Xp	6,0								
Tn	30								
Tv (auto)	21								
Td (auto)	3,5								
<table border="1" style="width: 100%; border-collapse: collapse;"> <tr> <td style="padding: 2px 10px;">Help</td> <td style="padding: 2px 10px;">Menu</td> <td style="padding: 2px 10px;">End</td> <td style="padding: 2px 10px;">T<sub>set</sub></td> <td style="padding: 2px 10px;">T<sub>fix</sub></td> </tr> </table>	Help	Menu	End	T <sub>set</sub>	T <sub>fix</sub>				
Help	Menu	End	T <sub>set</sub>	T <sub>fix</sub>					

**7.11.1.1 Proven settings for control parameters and pump (integral measurement probe)**

Instrument Type	Heat transfer liquid	Xp	Tn	Tv	Td	Pump level
		$_{-P}$	$t_n$	$t_u$	$t_d$	
RP 4090 CW	Water	9.0	60	42	6.3	8
RP 4090 CW	Ethanol	9.0	60	42	6.3	8
RP 4090 C	Water	9.0	60	42	6.3	8
RP 4090 C	Ethanol	9.0	60	42	6.3	8

Technical changes reserved!

**7.11.2 External control variable (External measurement probe)**

You only need to read further here if you have connected an external temperature probe or the actual temperature is read in from a module (and you have activated it as control variable according to Section 7.5.4).

Only modify the control parameters if you have knowledge of control techniques.

The control system for external actual values is implemented for improvement of the control behavior as a two-stage cascade controller. A "master controller" determines the "internal setpoint", from the temperature setpoint and the external temperature, passed to the slave controller. The control value of the slave controller controls the heating and cooling.

When a setpoint step change is specified, it may be that the optimum control would set a bath temperature, which might significantly exceed the temperature desired on the external vessel. There is a correction limitation, which specifies the maximum permissible deviation between the temperature on the external load and the heat transfer liquid temperature.

Command				
<div style="border: 1px solid black; padding: 5px;"> <p>Control Parameters</p> <p>Control para. sets</p> <p>Tv manual/auto</p> <p>Correction limitation</p> </div>	<div style="border: 1px solid black; padding: 5px;"> <p><b>Kpe</b> 0,50</p> <p>Tne 100</p> <p>Tve (auto) 83</p> <p>Tde (auto) 8,3</p> <p>Xpf 4,0</p> <p>Prop_E(a) 30</p> </div>			
Help	Menu	End	T <sub>set</sub>	T <sub>fix</sub>

**Control Parameters**

- Open the device parameter menu via the soft key **Menu** .
- With the cursor keys continue to: → **Control** → **Control Parameters** → **Control Parameters** .
- The adjacent window appears. Parameter endings: e = Master controller, f = Slave controller.
- Where applicable change parameters marked with (auto) to manual input with **Tv manual/auto** .
- Select the parameters to be changed with and confirm with .
- Then change the value in the following settings window and confirm with .
- **Correction limitation** see introduction.

### 7.11.2.1 Steps for setting the control parameters for external control

1. Activate external control ⇒ 7.5.4.
2. Setting the slave controller:
  - 2.1. Set parameters to **auto**; Check for thermostat type and change when necessary (RP....) ⇒ 9.1.1.
    - Choose heat transfer liquid with low viscosity and high thermal capacity. Ranking: water, ethanol, water-glycol, oil, Fluorinert®.
    - Set pump level as high as possible,
    - make bath circulation strong and fast,
    - choose hose length as short as possible, i.e. 2 x 1m,
    - choose hose cross section as large as possible, i.e. ½ inch,
    - throughput through the external load as large as possible.
  - 2.2. Xpf setting:
    - when oscillating with short period occur (i.e. 30 seconds) → Xpf lower, otherwise higher,
    - in case of bad thermal coupling and large thermal mass → high (i.e. 2...5, or even higher),
    - in case of good thermal coupling and small thermal mass → low (i.e. 0.2 ... 0.7),
    - when rapid temperature response is required simple internal control should be preferred. Otherwise select small Xpf (0.05 ... 0.1).
3. Setting the master controller (PIDT1-controller):
  - Start with setting Auto and proceed with Manual only when necessary.

3.1. Kpe setting:

- In case of oscillations with large period, i.e.10 min) → Kpe higher, otherwise lower.

3.2. Tne/ Tve/ Tde setting:

- Start with high numbers (Tne = 70s ... 200s; Tve = 50s ... 150s).
- With lower numbers → faster approach, otherwise slower approach with lower oscillations.
- Tve: to reduce overshoot → Tve higher, otherwise lower.
- Tde (damping for Tve): in general approximately 10% of Tve.

4. Correction limitation (or outflow temperature limitation) ⇔ 7.11.2 and temperature limits (Til/Tih) ⇔ 7.6.2:

- Make settings in accordance with the boundary conditions. Examples:

Heat transfer liquid	Correction limitation	Til	Tih
Water	depending on the external vessel size and the heat transfer liquid	+2°C	+95°C
Ethanol		Minimum	+40°C

- Tools to watch the time behavior: Graph mode of the Command console, LAUDA Wintherm PC-program.

## 7.12 Alarms, Warnings and Errors

The SelfCheck Assistant of your Proline Kryomat monitors more than 50 device parameters and triggers alarms, warnings or errors as appropriate.

All warnings and alarms are shown on the Command control element in plain text. Errors are shown in plain text on the Command control element, also, in an error list.



**Alarms:** Alarms are safety relevant. Pump, heater and refrigerating unit will be shut off.

**Warnings:** Warnings normally are not safety relevant. The device continues to operate.

**Errors:** If an error occurs, the pump, heater and refrigerating unit switch off automatically. Switch of the unit at the rotary mains switch. If the error is always present after switching on the device, please give information to the LAUDA Service for Constant Temperature Equipment (⇔ 9.3.7).

Find cause of alarm or warning and rectify where necessary. Then press  on the Master keyboard in order to remove the alarm message. Warning messages can be removed either on the Master keyboard

with  or on the Command board with .

Warnings may be ignored by pressing  or  on the Master keyboard or by activating the Screen Softkey on the Command control element. Warnings will not be repeated periodically.

### 7.12.1 Overtemperature protection and checking



The units are designed for operation with non-flammable and flammable liquids to DIN EN 61010-2-010.



### Overtemp. cut-off

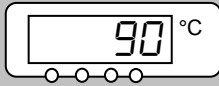

- Setting the overtemperature cut-off: Recommended setting: 5 °C above desired bath temperature.
- **Caution!!** The overheat switch-off point  $T_{max}$  is controlled by a system functioning independently of the bath control. Setting of the nominal temperature, however, can be limited via the functions  $T_{ih}$  and  $T_{il}$  ( $\Rightarrow$  7.6.2) independently of  $T_{max}$ .
- The cut-off point is displayed in the LED display on pressing the key .

### Changing the overtemperature cut-off point:

- For safety, and to guard against unintentional adjustment, the key must be held pressed during all the following entries. Now, briefly press . The display flashes and the overtemperature cut-off can be set with the keys or .
- Quit the change mode by pressing for a few seconds or automatically after 5 seconds, while you keep pressed.
- This somewhat complicated procedure is intended to prevent unintentional adjustment.



- Not higher than 25 °C below the fire point of the heat transfer liquid used ( $\Rightarrow$  6.2 and 6.3).
- The setting range is restricted to 5 °C above the upper limit of the working temperature range ( $T_{ih} \Rightarrow$  7.6.2).



### Overtemp. alarm



- If the bath temperature rises above the overtemperature cut-off:
  1. Alarm sounds as dual-tone signal.
  2. *EEPNP* for overtemperature appears in the display.
  3. The red LED above the fault triangle flashes.
    - $\rightarrow$  Heater switches off on both poles,
    - $\rightarrow$  Pump and refrigerating unit are switched off electronically.





- Rectify cause of fault.
- Wait until the bath temperature has cooled below the cut-off point or set the cut-off point higher than the bath temperature. When *EEPNP* is shown in the display:
  - Unlock with the key.











Unlocking is not possible on the Command control element!



- Before longer periods of unsupervised operation, the **overtemperature protection should be checked. To do this:**

	<ul style="list-style-type: none"> <li>- Slowly lower <math>T_{max}</math>, as described above. → Cut-off at the bath temperature should occur.</li> <li>- Step 1 – 2 (see above) must follow.</li> <li>- Set the overtemperature cut-off higher than the bath temperature again and wait until <b>TEMP</b> appears in the display.</li> </ul>
	<ul style="list-style-type: none"> <li>- Unlock with the  key.</li> </ul> <p>Unlocking is not possible on the Command control element!</p>
<b>Command</b>	- <span style="border: 1px solid black; padding: 2px;">Overtemperature alarm!</span>
	- <span style="border: 1px solid black; padding: 2px;">Overtemperature alarm!</span> is shown in the display and signifies that <u>unlocking is only possible on the Master control panel.</u>

### 7.12.2 Low-level alarm and low-level checking

 	<ul style="list-style-type: none"> <li>- If the liquid level falls so far that the heating element is no longer completely covered with liquid, an alarm is initiated:</li> </ul>
<div style="border: 1px solid gray; padding: 5px; width: fit-content; margin: 0 auto;"> <p style="text-align: center; margin: 0;">Level alarm</p> <div style="border: 1px solid black; padding: 2px; text-align: center; margin: 0 auto;"> <span style="font-family: monospace; font-size: 1.2em;">LEVEL</span> °C         </div> <div style="display: flex; justify-content: center; gap: 5px; margin-top: 5px;"> <span style="font-size: 0.8em;">●</span> <span style="font-size: 0.8em;">○</span> <span style="font-size: 0.8em;">○</span> <span style="font-size: 0.8em;">○</span> </div> </div>	<ol style="list-style-type: none"> <li>1. The alarm sounds as a dual-tone signal.</li> <li>2. Display for <b>LEVEL</b> (low level) is shown when the bath contains too little liquid.</li> <li>3. The red LED  above the fault triangle  flashes. → Heater switches off on both poles, → VarioFlex pump and refrigerating unit are switched off.</li> </ol>
 	<ul style="list-style-type: none"> <li>- Find the cause of the fault and, where necessary, top up for missing liquid ⇒ 6.2 and 6.3.</li> </ul>
	<ul style="list-style-type: none"> <li>- Press the Enter key.</li> <li>- Also, press this key if the unit has been switched off in the fault state.</li> </ul>
	<ul style="list-style-type: none"> <li>- <b>Checking the safety system at regular intervals</b> by lowering the bath level. To do this, fit a hose to the drain point and slowly run off the heat transfer liquid into a suitable container via the drain-point tap at the front.</li> <li>- Step 1 – 2 must follow.</li> </ul>
	<ul style="list-style-type: none"> <li>- With this test, the bath temperature must not be below 0 °C or above 50 °C, otherwise there is a risk of injury!</li> <li>- If irregularities arise during the checking of the safety devices, switch off the unit immediately and pull out the mains plug.</li> <li>- Have the equipment checked by LAUDA Service for Constant Temperature Equipment.</li> </ul>
<b>Command</b>	- <span style="border: 1px solid black; padding: 2px;">Low-level alarm!</span>
	- <span style="border: 1px solid black; padding: 2px;">Low-level alarm!</span> is shown in the display and signifies that <u>unlocking is only possible on the Master control panel.</u>

### 7.12.3 High-level settings





Different reactions can be chosen when the level sensor detects the height of the heat transfer liquid level. Depending on the setup, heat transfer liquid or operation conditions, one of the following settings may be suitable:

Setting	Master settings	Command settings	Reaction and application recommendation
No warning	nHnon	<b>none</b>	Select only when no safety sensitive application. I.e. water as heat transfer liquid.
Warning	nHLUJ	<b>Warning</b>	Acoustic and optical warning as long as the level goes down. This is the factory setting.
Warning and heater off	nHLUJH	<b>Warning + heater off</b>	<i>Warning</i> and additional <i>heater off</i> as long as the level goes down. Recommended for flammable heat transfer liquids with much higher flash point and temperatures above 100 °C.
Alarm	nHRLA	<b>Alarm</b>	<i>Alarm</i> switches off the pump and the heater until the alarm is removed by pressing  on the Master keyboard. Recommended for external loads and flammable liquids.

**Command**

Over level handling

none  
**Warning**  
Warn.+ Heater off  
Alarm

- **Over level handling**
- Open the device parameter menu via the soft key  **Menu**.
- With the cursor keys continue to → **Settings** → **Over level handling**.
- The shown window appears
- Select the preferred parameter with  or  and confirm with .
- See introduction for details.

Help
Menu
End
T<sub>set</sub>
T<sub>fix</sub>



### 7.12.4 High-level warning or alarm



3 Sec.

- Acoustic warning signal sounds for 3 seconds when the liquid level rises so far that the uppermost switching point of the level sensor has been reached.

---









- Or in case the warning function as described in 7.12.3 was chosen:
- The acoustic signal with dual-tone sounds.

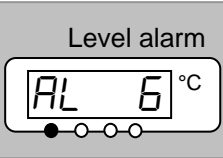





Level warning



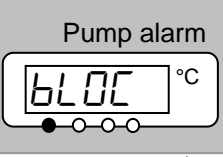







- Warning *LUArn 103* (high level) appears when the bath contains too much liquid.
- The *LUArn* flashes by turns with the numeral.

<p>Level alarm</p>  	<ul style="list-style-type: none"> <li>- In case the alarm function as described in 7.12.3 was chosen:</li> <li>- The acoustic signal with dual-tone sounds.</li> <li>- The red LED  above the fault triangle  flashes.             <ul style="list-style-type: none"> <li>→ Heater switches off on both poles,</li> <li>→ Pump and refrigerating unit are switched off electronically.</li> </ul> </li> <li>- Find the cause of the fault. Possible causes may be:             <ol style="list-style-type: none"> <li>1. Volume expansion on heating.</li> <li>2. Feed to an external vessel may be interrupted so that only return suction is possible.</li> <li>3. Heat transfer liquid taking up moisture.</li> </ol> </li> <li>- If Alarm: Press Enter key. Warnings disappear automatically when the cause is gone.</li> <li>- Also, press this key if the unit has been switched off in the fault state. Warnings disappear automatically when the cause is gone.</li> </ul>
<p><b>Command</b></p>	<ul style="list-style-type: none"> <li>- <input type="text" value="High-level warning/alarm"/></li> </ul>
	<ul style="list-style-type: none"> <li>- The display shows <input type="text" value="Warning. To release press Enter key"/> <input type="text" value="Security 3 Level too high"/></li> <li>or <input type="text" value="Alarm AL 6: Level too high"/> is shown in the display and signifies that <u>unlocking is only possible on the Master control panel.</u></li> </ul>

**7.12.5 Pump-motor supervision: Overload or blockage**

   	<ul style="list-style-type: none"> <li>- The SelfCheck Assistant monitors the VarioFlex Pump:</li> <li>1. Alarm sounds as dual-tone signal for pump-motor overload or blockage.</li> <li>2. Display of <i>BLDC</i> signals blockage.</li> <li>3. The red LED  above the fault triangle  flashes.             <ul style="list-style-type: none"> <li>→ Heater switches off on both poles,</li> <li>→ Pump and refrigerating unit are switched off electronically.</li> </ul> </li> <li>- Find the cause of the fault. Perhaps the viscosity of the heat transfer liquid is too high or the pump is blocked.</li> <li>- Press the Enter key.</li> <li>- Also press this key if the unit has been switched off in the fault state.</li> </ul>
<p><b>Command</b></p>	<ul style="list-style-type: none"> <li>- <input type="text" value="Pump-motor alarm!"/></li> </ul>
	<ul style="list-style-type: none"> <li>- <input type="text" value="Pump-motor alarm"/> is shown in the display and signifies that <u>unlocking is only possible on the Master control panel.</u></li> </ul>

**7.12.6 Pump-motor supervision: Dry running**

	<ul style="list-style-type: none"> <li>- The SelfCheck Assistant monitors the VarioFlex pump:</li> </ul>
<p>Pump alarm</p> 	<ol style="list-style-type: none"> <li>1. Alarm sounds as dual-tone signal when the pump runs without liquid. This can only occur when the float level measurement has failed.</li> <li>2. The display of <i>PULEU</i> signals that the SelfCheck Assistant has detected a pump low level.</li> <li>3. The red LED  above the fault triangle  flashes. <ul style="list-style-type: none"> <li>→ Heater switches off on both poles,</li> <li>→ Pump and refrigerating unit are switched off electronically.</li> </ul> </li> </ol>
   	<ul style="list-style-type: none"> <li>- The cause of the failure of the level measurement with the floatation sensor must be found and rectified. Perhaps foreign bodies in the bath block it.</li> <li>- Press the Enter key.</li> <li>- Also press this key if the unit has been switched off in the fault state.</li> </ul>
<p><b>Command</b></p>	<ul style="list-style-type: none"> <li>- <span style="border: 1px solid black; padding: 2px;">Alarm! Low level (pump)</span></li> </ul>
	<ul style="list-style-type: none"> <li>- <span style="border: 1px solid black; padding: 2px;">Alarm! Low level (pump)</span> is shown in the display and signifies that <u>unlocking is only possible on the Master control panel.</u></li> </ul>

### 7.12.7 Compressor Overtemp

<p><b>Command</b></p>	<span style="border: 1px solid black; padding: 2px;">Error! Comp1 overtemp</span>
	<ul style="list-style-type: none"> <li>- <span style="border: 1px solid black; padding: 2px;">Error! Comp1 overtemp</span> is shown in the display. The cause may be a technical malfunction or an extremely situation in temperature control. Switch off the unit and wait min. 15 minutes to restart it again so that the compressor has time enough to cool down again.</li> <li>- This error may affect stage 1 (Error 68) or stage 2 (Error 69).</li> </ul> <p>If the error is always present after switching on the device, please give information to the LAUDA Service for Constant Temperature Equipment (⇒ 9.3.7).</p>

### 7.12.8 Three-phase current

<p><b>Command</b></p>	<span style="border: 1px solid black; padding: 2px;">Error! Three-phase current</span>
	<ul style="list-style-type: none"> <li>- <span style="border: 1px solid black; padding: 2px;">Error! Three-phase current</span> is shown in the display, signed by number 70. The cause is the wrong direction of the current rotation field. It has to be clockwise!</li> <li>- Another reason may be the missing of one phase of the voltage supply.</li> </ul>

### 7.12.9 Fault list „Alarms and Warnings“

#### Alarms

Message	Meaning
P <sub>U</sub> LEU	Pump too fast (low level)
LEUEL	Low level alarm in the level sensor
TEPPP	Overtemperature (t > t <sub>max</sub> )
BLOC	Pump blocked (no rotation)
CFR IL	Command control element connection interrupt
AL 1	Temperature signal of external Pt100 missing
AL 2	Temperature signal of analogue input missing
AL 3	Temperature signal of serial port missing
AL 4	Analogue module: Current input 1 interrupted
AL 5	Analogue module: Current input 2 interrupted
AL 6	Protection system: High bath level
AL 7	Error digital input
AL 8	Refill fail

#### Warnings in the “Master-Display”

Message	Meaning
LD 1	Overflow of CAN receipt
LD 2	Watchdog-Reset
LD 3	til-limitation active
LD 4	tih-limitation active
LD 5	Heatsink temperature is superheated
LD 11	Software version of protection system too old
LD 12	Software version of operating system too old
LD 13	Software version of heating system too old
LD 14	Software version of analogue Interface too old
LD 15	Software version of RS 232 too old
LD 16	Software version of contact I/O module too old
LD 17	Software version of valve 0 too old
LD 18	Software version of valve 1 too old
LD 19	Software version of valve 2 too old
LD 20	Software version of valve 3 too old
LD 21	Software version of pump 0 too old
LD 22	Software version of pump 1 too old
LD 23	Software version of pump 2 too old
LD 24	Software version of pump 3 too old

#### Warnings in the “Safety system”

Message	Meaning
LD 101	Overflow of CAN receipt
LD 102	Watchdog-Reset
LD 103	Close to bath overflow
LD 104	Bath level is approaching switch off level or is out of optional range
LD 105	Heater 1 break
LD 106	Heater 2 break
LD 107	Heater 3 break
LD 110	Software version of control system too old
LD 112	Software version of operating system too old
LD 113	Software version of heating system too old
LD 114	Software version of analogue interface too old
LD 115	Software version of RS 232 too old
LD 116	Software version of contact I/O module too old
LD 117	Software version of valve 0 too old
LD 118	Software version of valve 1 too old
LD 119	Software version of valve 2 too old
LD 120	Software version of valve 3 too old
LD 121	Software version of pump 0 too old
LD 122	Software version of pump 1 too old
LD 123	Software version of pump 2 too old
LD 124	Software version of pump 3 too old

### Warnings in the "Command-Display"

Message	Meaning
LJ201	Overflow of CAN receipt
LJ202	Watchdog-Reset
LJ203	RTC Voltage drop recognized: Battery failure
LJ210	Software version of control system too old
LJ211	Software version of protection system too old
LJ213	Software version of heating system too old
LJ214	Software version of analogue interface too old
LJ215	Software version of RS232 too old
LJ216	Software version of contact I/O too old
LJ217	Software version of valve 0 too old
LJ218	Software version of valve 1 too old
LJ219	Software version of valve 2 too old
LJ220	Software version of valve 3 too old
LJ221	Software version of pump 0 too old
LJ222	Software version of pump 1 too old
LJ223	Software version of pump 2 too old
LJ224	Software version of pump 3 too old

### Warnings from "Cooling system"

Message	Meaning
LJ301	Overflow of CAN receipt
LJ302	Watchdog-Reset
LJ303	sm.stell_min still not determined → Adaption run necessary
LJ304	Pressure switch 1 operated
LJ305	Condenser dirty (→ cleaning)
LJ310	Software version of control system too old
LJ311	Software version of protection system too old
LJ312	Software version of operation system
LJ314	Software version of analogue interface too old
LJ315	Software version of RS232 too old
LJ316	Software version of contact I/O too old
LJ317	Software version of valve 0 too old
LJ318	Software version of valve 1 too old
LJ319	Software version of valve 2 too old
LJ320	Software version of valve 3 too old
LJ321	Software version of pump 0 too old
LJ322	Software version of pump 1 too old
LJ323	Software version of pump 2 too old
LJ324	Software version of pump 3 too old

### Warnings from "Analogue-Module"

Message	Meaning
LJ401	Overflow of CAN receipt
LJ402	Watchdog-Reset
LJ410	Software version of control system too old
LJ411	Software version of protection system too old
LJ412	Software version of operation system
LJ413	Software version of heating system too old
LJ415	Software version of RS232 too old
LJ416	Software version of contact I/O too old
LJ417	Software version of valve 0 too old
LJ418	Software version of valve 1 too old
LJ419	Software version of valve 2 too old
LJ420	Software version of valve 3 too old
LJ421	Software version of pump 0 too old
LJ422	Software version of pump 1 too old
LJ423	Software version of pump 2 too old
LJ424	Software version of pump 3 too old

### Warnings from "RS232/485-Module"

Message	Meaning
LJ501	Overflow of CAN receipt
LJ502	Watchdog-Reset
LJ510	Software version of control system too old
LJ511	Software version of protection system too old
LJ512	Software version of operation system
LJ513	Software version of heating system too old
LJ514	Software version of analogue interface too old
LJ516	Software version of contact I/O too old
LJ517	Software version of valve 0 too old
LJ518	Software version of valve 1 too old
LJ519	Software version of valve 2 too old
LJ520	Software version of valve 3 too old
LJ521	Software version of pump 0 too old
LJ522	Software version of pump 1 too old
LJ523	Software version of pump 2 too old
LJ524	Software version of pump 3 too old

**Warnings from “Contact I/O-Module”**

Message	Meaning
LJ601	Overflow of CAN receipt
LJ602	Watchdog-Reset
LJ610	Software version of control system too old
LJ611	Software version of protection system too old
LJ612	Software version of operation system
LJ613	Software version of heating system too old
LJ614	Software version of analogue interface too old
LJ615	Software version of RS232 too old
LJ617	Software version of valve 0 too old
LJ618	Software version of valve 1 too old
LJ619	Software version of valve 2 too old
LJ620	Software version of valve 3 too old
LJ621	Software version of pump 0 too old
LJ622	Software version of pump 1 too old
LJ623	Software version of pump 2 too old
LJ624	Software version of pump 3 too old

**Warnings from “Solenoid valve” Code 7, 8, 9XX)**

Message	Meaning
LJ701	Overflow of CAN receipt
LJ702	Watchdog-Reset
LJ710	Software version of control system too old
LJ711	Software version of protection system too old
LJ712	Software version of operation system
LJ713	Software version of heating system too old
LJ714	Software version of analogue interface too old
LJ715	Software version of RS232 too old
LJ716	Software version of contact I/O too old
LJ721	Software version of pump 0 too old
LJ722	Software version of pump 1 too old
LJ723	Software version of pump 2 too old
LJ724	Software version of pump 3 too old

## 7.13 RS 232/ RS 485 Interface

### 7.13.1 Connecting cables and interface test RS 232

Signal	Computer				Thermostat		Signal
	9-pin sub-D-socket		25-pin sub-D-socket		9-pin sub-D-socket		
	①	②	①	②	①	②	
R x D	2	2	3	3	2	2	T x D
T x D	3	3	2	2	3	3	R x D
DTR	4		20		4		DSR
Signal Ground	5	5	7	7	5	5	Signal Ground
DSR	6		6		6		DTR
RTS	7		4		7		CTS
CTS	8		5		8		RTS

① with hardware handshake: For connecting a thermostat to the PC use 1:1 cable and not a null-modem cable!

② without hardware handshake: the computer / PC must be set to the operating mode "without hardware handshake".



- Use screened connecting cable.
- Connect screen to connector case.
- The connections are galvanically isolated from the rest of the electronics.
- Any pins not in use must not be connected!

When a PC is connected up the RS232 interface can easily be **tested** using the Microsoft Windows operating system. On Windows® 95/ 98/ NT/ XP with the "Hyper Terminal" program.

### 7.13.2 Protocol RS 232



- The interface operates with one stop bit, no parity bit and 8 data bits.
- Transfer rate either 2400, 4800, 9600 (factory setting) or 19200 baud as selected.
- The RS232 interface can be operated with or without hardware handshake, (RTS/CTS).
- The command from the computer must be terminated with CR, CRLF, or LFCR.
- The response of the thermostat is always terminated with CRLF.

CR = Carriage Return (Hex: 0D)

LF = Line Feed (Hex: 0A)

**Example:** Transfer of setpoint 30,5 °C to the thermostat

Computer	Thermostat
"OUT_SP_00_30.5"CRLF	⇒
⇐	"OK"CRLF

**7.13.3 Connecting cable RS 485**

Thermostat	
9-pin sub-D-socket	
Pin	Data
1	Data A (-)
5	SG (Signal Ground) optional
6	Data B (+)



- Use screened connecting cables.
- Connect screen to connector case.
- The connections are galvanically isolated from the rest of the electronics.
- Any pins not in use must not be connected!

An **RS 485** bus always requires bus termination in the form of a termination network which ensures a defined rest status in the high-resistance phases of bus operation. The bus termination is as follows:

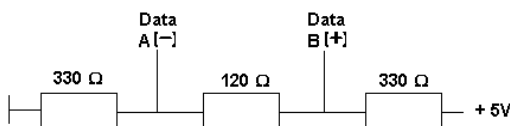

This termination network is usually incorporated on the PC plug-in card (RS 485).

**7.13.4 Protocol RS 485**



- The interface operates with one stop bit, no parity bit and 8 data bits.
- Transfer rate either 2400, 4800, 9600 (Factory setting) or 19200 baud as selected.
- The RS 485 commands are always preceded by the device address. There is provision for 127 addresses. The address must always have three digits. (A000\_...to A127\_...).
- The command from the computer must be terminated with CR.
- The response of the thermostat is always terminated with CR.

CR = Carriage Return (Hex: 0D)

**Example:** Transfer of setpoint 30.5 °C to the thermostat with address 15.

Computer	Thermostat
"A015_OUT_SP_00_30.5"CR	⇒
⇐	"A015_OK"CR

### 7.13.5 Write commands (Data commands to the thermostat)

Command	Explanation
OUT_PV_05_XXX.XX	External temperature to be set through the interface.
OUT_SP_00_XXX.XX	Setpoint transfer with up to 3 places before the decimal point and up to 2 places behind.
OUT_SP_01_XXX	Pump output step 1 to 8.
OUT_SP_02_XXX	Operation mode cooling (0 = OFF / 1 = ON / 2 = AUTOMATIC).
OUT_SP_04_XXX	TiH outflow temperature high limit.
OUT_SP_05_XXX	TiL outflow temperature low limit.
OUT_PAR_00_XXX.X	Setting of control parameter Xp.
OUT_PAR_01_XXX	Setting of control parameter Tn (5...180s; 181 = Off).
OUT_PAR_02_XXX	Setting of control parameter Tv.
OUT_PAR_03_XXX.X	Setting of control parameter Td.
OUT_PAR_04_XXX.XX	Setting of control parameter KpE.
OUT_PAR_05_XXX	Setting of control parameter TnE (0...998s; 999 = Off).
OUT_PAR_06_XXX	Setting of control parameter TvE.
OUT_PAR_07_XXX.X	Setting of control parameter TdE.
OUT_PAR_09_XXX.X	Setting of the max. outflow temperature limit.
OUT_PAR_10_XXX.X	Setting of control parameter XpF.
OUT_PAR_11_XXX	Setting of control parameter TnF (5...180s; 181 = Off).
OUT_PAR_12_XXX	Setting of control parameter TvF.
OUT_PAR_13_XXX.X	Setting of control parameter TdF.
OUT_PAR_14_XXX.X	Setting of the setpoint offset.
OUT_MODE_00_X	Keys Master: 0 = free / 1 = inhibited (corresponds to "KEY").
OUT_MODE_01_X	Control: 0 = internal / 1 = external Pt100 / 2 = external Analogue / 3 = external Serial.
OUT_MODE_03_X	Keys Command: 0 = free / 1 = inhibited.
OUT_MODE_04_X	Setpoint offset source: 0 = normal / 1 = ext. Pt / 2 = ext. analog / 3 = ext. serial.
START	Switches the unit on (after Standby). <b>See safety information ⇒ 7.5.3.</b>
STOP	Switches the unit into Standby (pump, heater, cooling unit OFF).
RMP_SELECT_X	Selection of the program (1...5) to which the further instructions apply. When the unit is switched on, program 5 is selected automatically.
RMP_START	Start the programmer.
RMP_PAUSE	Hold (pause) the programmer.
RMP_CONT	Restart the programmer after pause.
RMP_STOP	Terminate the program.
RMP_RESET	Delete the program (all Segments).
RMP_OUT_00_XXX.XX_XXXXX_XXX.XX_X	Set a programmer segment (temperature, time, tolerance and pump level). A segment is added and appropriate values are applied to it.
RMP_OUT_02_XXX	Number of times the program runs: 0 = unlimited / 1...250.
RMP_OUT_06_XXX.XX	Programmer tolerance setting (0 = off / 0.01 °C...450.00 °C). All following

Command	Explanation
	segments receive this tolerance setting.



- For ”\_“ use also ” ” (blank character).
- Response from thermostat ”OK“ or in case of error ” ERR\_X“ (RS 485 interface e.g. ”A015\_OK“ or in case of error ”A015\_ERR\_X“).

**Permitted data formats:**

-XXX.XX	-XXX.X	-XXX.	-XXX	XXX.XX	XXX.X	XXX.	XXX
-XX.XX	-XX.X	-XX.	-XX	XX.XX	XX.X	XX.	XX
-X.XX	-X.X	-X.	-X	X.XX	X.X	X.	X
-.XX	-.X	.XX	.X				

### 7.13.6 Read commands (Data requested from the thermostat)

Command	Explanation
IN_PV_00	Read bath temperature (outflow temperature).
IN_PV_01	Indication of the controlled temperature (int./ ext. Pt/ ext. Analogue/ ext. Serial).
IN_PV_03	Read external temperature TE (Pt100).
IN_PV_04	Read external temperature TE (Analogue input).
IN_PV_05	Read bath level.
IN_PV_10	Read bath temperature (outflow temperature) <b>in 0.001 °C.</b>
IN_PV_13	Read external temperature TE (Pt100) <b>in 0.001 °C.</b>
IN_SP_00	Read temperature setpoint.
IN_SP_01	Read current pump power stage.
IN_SP_02	Read cooling operation mode (0 = OFF / 1 = ON / 2 = AUTOMATIC).
IN_SP_03	Read current overtemperature switch-off point.
IN_SP_04	Read current outflow temperature limit TiH.
IN_SP_05	Read current outflow temperature limit TiL.
IN_PAR_00	Read current value of Xp.
IN_PAR_01	Read current value of Tn (181 = OFF).
IN_PAR_02	Read current value of Tv.
IN_PAR_03	Read current value of Td.
IN_PAR_04	Read current value of KpE.
IN_PAR_05	Read current value of TnE (999 = OFF).
IN_PAR_06	Read current value of TvE.
IN_PAR_07	Read current value of TdE.
IN_PAR_09	Interrogation of the maximum outflow temperature limit.
IN_PAR_10	Read current value of XpF.
IN_PAR_11	Read current value of TnF (181 = OFF).
IN_PAR_12	Read current value of TvF.
IN_PAR_13	Read current value of TdF.
IN_PAR_14	Interrogation of the setpoint offset.
IN_DI_01	Status of contact input 1: 0 = open/ 1 = closed.
IN_DI_02	Status of contact input 2: 0 = open/ 1 = closed.
IN_DI_03	Status of contact input 3: 0 = open/ 1 = closed.
IN_DO_01	State of Contact output 1:

Command	Explanation
	0 = make-contact open/ 1 = make-contact closed.
IN_DO_02	State of Contact output 2: 0 = make-contact open/ 1 = make-contact closed.
IN_DO_03	State of Contact output 3: 0 = make-contact open/ 1 = make-contact closed.
IN_MODE_00	Keys Master: 0 = free / 1 = inhibited.
IN_MODE_01	Control: 0 = int. / 1 = ext. Pt100 / 2 = ext. Analogue / 3 = ext. Serial.
IN_MODE_02	Standby: 0 = Unit ON / 1 = Unit OFF.
IN_MODE_03	Keys Command: 0 = free / 1 = inhibited.
IN_MODE_04	Setpoint offset source: 0=normal/1=ext.Pt/2=ext.analogue/3=ext.serial.
TYPE	Read equipment type.
VERSION_R	Read software type of control system.
VERSION_S	Read software type of protection system.
VERSION_B	Read software type of Command.
VERSION_T	Read software type of cooling system.
VERSION_A	Read software type of analogue module.
VERSION_V	Read software type of RS232/485 module.
VERSION_D	Read software type of digital module.
VERSION_M_0	Read software type of solenoid valve (Cooling water).
VERSION_M_1	Read software type of solenoid valve (Automatic refill).
VERSION_M_2	Read software type of solenoid valve (Level controller).
STATUS	Read equipment status 0 = OK, -1 = error.
STAT	Read error diagnosis response: XXXXXXXX → X = 0 no error, X = 1 error. 1 Char = error. 2 Char = Alarm. 3 Char = Warning. 4 Char = over temperature. 5 Char = low-level error. 6 Char = high-level error (at adjustment alarm). 7 Char = no external control variable.
RMP_IN_00_XXX	Read a program segment XXX (response: e. g. 030.00_010.00 → set point temperature 30.00°C, time = 10 min, tolerance = 5.00°C, pump level = 1).
RMP_IN_01	Read the current segment number.
RMP_IN_02	Read the set number of program runs.
RMP_IN_03	Read the current program run.
RMP_IN_04	Read the program to which further instructions apply.
RMP_IN_05	Read which program is running now (0=none).
LOG_IN_00_XXXX	Query a measuring point XXXX from data logger (Reply: e. g. 020.00_021.23_030.50 => set point temperature = 20.00°C, bath temperature = 21.23°C, external temperature = 30.5°C).
LOG_IN_01	Query all measuring points from data logger As a difference to the command "LOG_IN_00", a tabulator is used here as separator instead of ,_'. The measuring points are separated by CR and LF. The end is marked by CR LF CR LF.
LOG_IN_02	Query the start time from the data logger (Reply: e.g. 20_14_12_20 → day 20, 14:12:20).
LOG_IN_03	Query the acquisition interval from the data logger (Reply in seconds).



- For ”\_“ use also ” ” (blank character).
- The equipment response is always in the fixed decimal format ”XXX.XX“ or for negative values ”-XXX.XX“ or ”ERR\_X“. (RS 485 interface e.g.. ”A015\_XXX.XX“ or ”A015\_-XXX.XX“ or ”A015\_ERR\_X“).

### 7.13.7 Error messages

Message	Explanation
ERR_2	Wrong input (e.g. buffer overflow)
ERR_3	Wrong command
ERR_5	Syntax error in value
ERR_6	Illegal value
ERR_8	Module (ext. temperature) not available
ERR_30	Programmer, all segments occupied.
ERR_31	Set point not possible, analogue set point input ON.
ERR_32	TiH <= TiL.
ERR_33	No external sensor
ERR_34	Analogue value not available
ERR_35	Auto is selected
ERR_36	No set point input possible. Programmer is running or is pausing.
ERR_37	No start from programmer possible, analogue setpoint input is switched on.

### 7.13.8 Driver software for LABVIEW®

An individual, easy-to-use control and automation software for operating the PROLINE device can be programmed with the aid of the National Instruments program development tool LABVIEW® (<http://sine.ni.com/apps/we/nio.vp?cid=1381&lang=US>).

In order to make program operation possible on the RS 232/ RS 485 interface, LAUDA provides drivers specially designed for LABVIEW® which can be downloaded free of charge under [www.lauda.de/spec-e.htm](http://www.lauda.de/spec-e.htm).

## 8 Interface modules

### 8.1 Installing of modules



When switching off only on the master head, using the switch at the front or back, there is still voltage present on the unit or head.

Set the rotary switch on the front panel to "OFF = 0" and withdraw the mains plug.

The master can be supplemented with further interface modules, which are simply inserted at the back of the master control head into two module slots.



- Switch off the Kryomat at the rotary switch on the front panel and withdraw the mains plug.
- Touch the earthed bath cover of the Proline thermostat to discharge any electrostatic charge.
- Remove the module from its packaging.
- Insert a screwdriver into the lower recess of the module cavity and prise up the plastic cover. The cover can then be pulled off downwards.



- Pull out the plug of the bus connecting cable from the plastic cover.

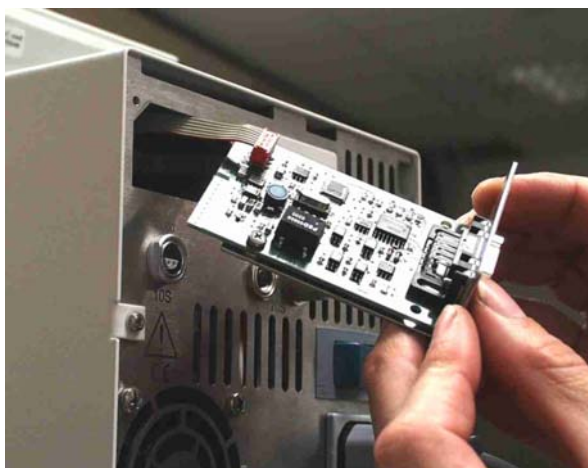

- Plug on the bus connecting cable (red plug onto red socket).
- Insert the module and secure with the two crosshead screws.
- Connect the mains plug again and switch on the thermostat.



The plugs are protected against reverse polarity. The plugs have a ridge, which slides into a groove in the socket.

### 8.2 Menu structure for all modules (only Command)

All existing menu points are illustrated. However, the Command Console masks out menu points, which cannot be executed. Further information can be found in the following sections.

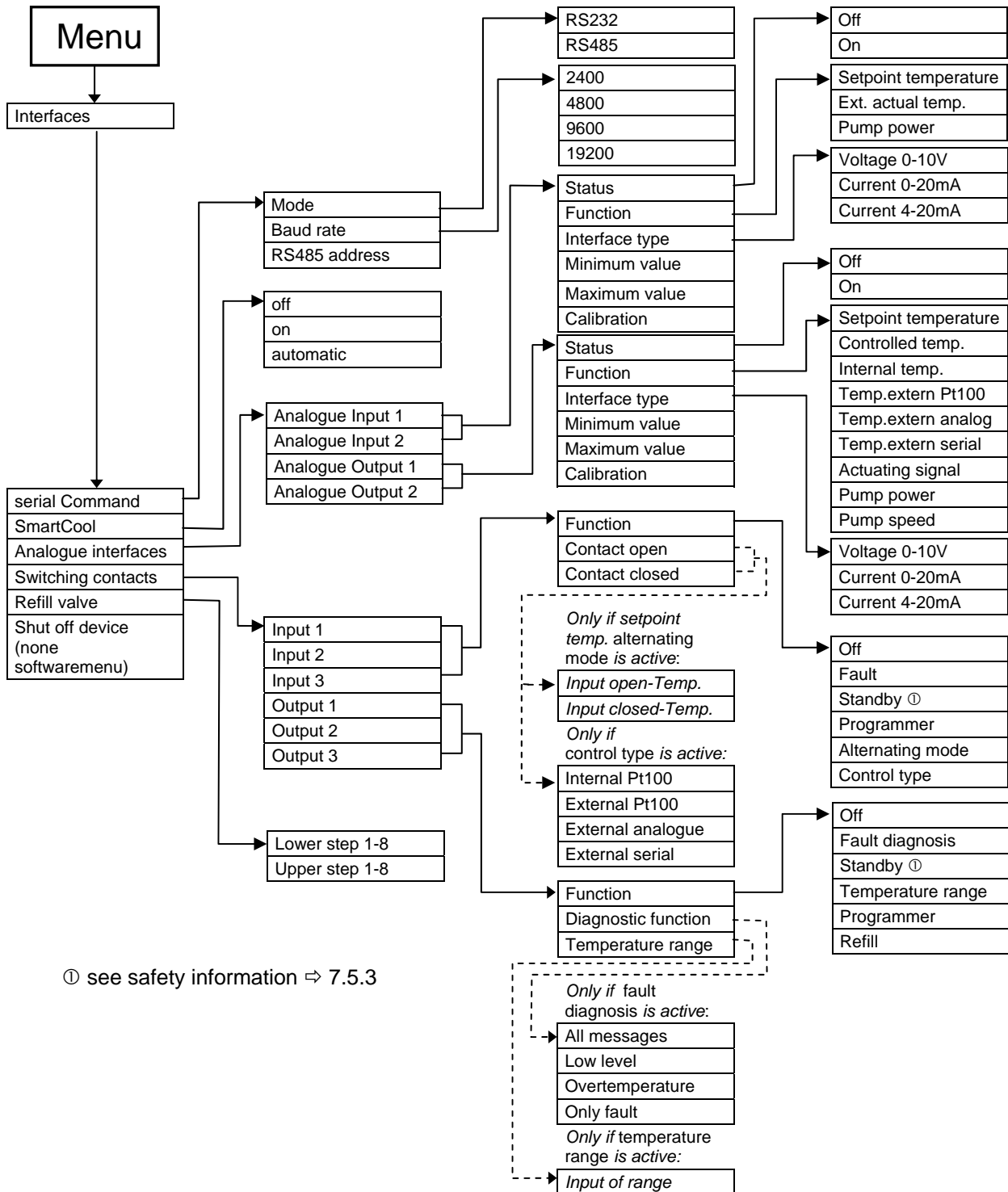



View of the socket (front) or solder side of plug:

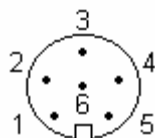

Pin 1	Output 1
Pin 2	Output 2
Pin 3	0 V reference potential
Pin 4	Input 1
<b>Pin 5</b>	<b>+24 V (max. 0.1 A)</b>
Pin 6	Input 2

 Use shielded lines. Connect shielding with connector housing!

## 8.5 Contact module

### 8.5.1 Contact module LRZ 915 with three inputs and three outputs

Contact module Cat. no. LRZ 915) on 15 pole SUB-D socket. With three relay contact outputs (changeover, max. 30V/ 0.2A) and three binary inputs for control via external voltage-free contacts.

The following functions are made available by the inputs:

- Set fault with function: Master: *F ALA* or Command: **Fault**.
- Set Stand by with function: *F Stb* or **Stand by**.
- Control programmer (Input 1 activates programmer 1, input 2 activates programmer 2 etc. At the first “close” the programmer gets starting, “open” removes it in “pause”. The next “close” initiate “continue”) with function: *F PrG* or **Programmer**.
- Control alternating mode (the switching state contact “open” or “closed” allot to two different setpoint temperatures): *F tZC* or **alternating mode**.
- Controller mode (the switching state input “open” or “closed” can allotted to two different control temperature sources. E. g. internal ↔ external control): *F Con* or **type of control**.

The following functions are made available by the outputs:

- Signal various fault states: *F d iA* or **fault diagnosis**.
- Signaling standby: *F Stb* or **Standby**.
- Providing status of the window discriminators (inside ↔ outside): *F Lu i* or **temperature range**.
- Providing the programmer status: *F PrG* or **Programmer**.
- Signaling refill of heat transfer liquid: *F FiL* or **Refill**.

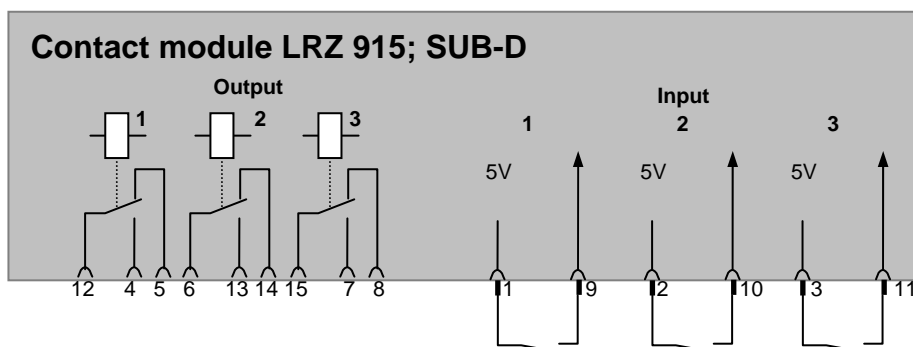

### Contact inputs and outputs

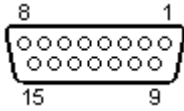

- View of the socket from the plug side or of the plug on the solder side.
- A suitable 15-pole Sub-D plug can be obtained together with a suitable housing:  
Order no. EQM 030 and plug housing order no. EQG 017.

### 8.5.2 Namur-Contact module LRZ 914 with only one input and one output

Contact module (Cat. no. LRZ 914) with connector to NAMUR NE28. Functionality as LRZ 915, but only one output and one input on each of two DIN sockets.

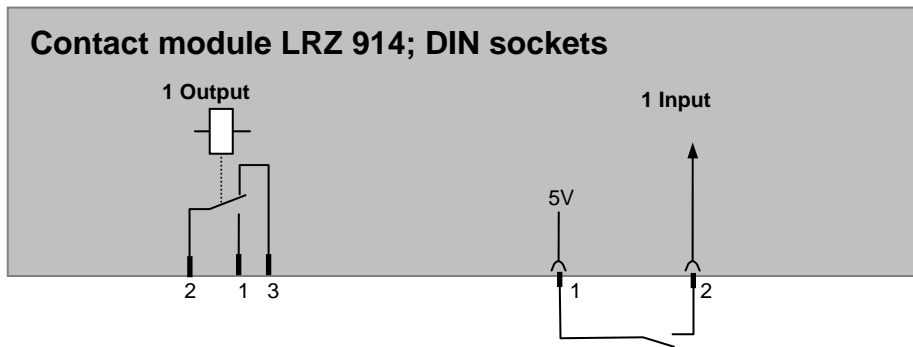

### Contact inputs and outputs:

Output	Input	
<ul style="list-style-type: none"> <li>- View on flange plug (Front) or solder side coupler socket.</li> <li>- Max. 30 V; 0.2 A.</li> </ul> <p>Coupler socket Catalogue number EQD 047.</p>	<ul style="list-style-type: none"> <li>- View on flange plug (Front) or solder side coupler socket.</li> <li>- Signal circa 5 V, 10 mA. Do not use pin 3!</li> </ul> <p>Coupling plug Catalogue number EQS 048.</p>	
	<p>1 = n.o. (make)</p> <p>2 = common,</p> <p>3 = n.c. (break)</p>	



- Use shielded lines. Connect shielding with connector housing. Cover unused plug connections with protecting caps!

## 9 Maintenance

### 9.1 Device status

The thermostat can be conveniently checked with the Command Console.

#### 9.1.1 Interrogating the device type

→ **Settings** → **Device status** → **Device type**

#### 9.1.2 Software version

→ **Settings** → **Device status** → **Software version**.

The versions of the control system (**Control**), safety system (**Safety**), Command Console (**Command**), cooling system (**Cool**) and, where applicable, other connected modules are displayed.

#### 9.1.3 Serial numbers

→ **Settings** → **Device status** → **Serial numbers**.

The serial number of the Master (**Master**), Command Console (**Command**), cooling system (**Cool**) and other connected modules are displayed.

#### 9.1.4 Device data

Command					– <b>Device data</b>																																																	
<table border="1"> <tr> <td>T ext Pt</td> <td>25.70</td> <td>T int</td> <td>-8</td> <td></td> <td></td> </tr> <tr> <td>T ext analog</td> <td>---.---</td> <td>Mains U(%)</td> <td>100.74</td> <td></td> <td></td> </tr> <tr> <td>T ext serial</td> <td>---.---</td> <td>Mains frequ.</td> <td>50</td> <td></td> <td></td> </tr> <tr> <td>T cont. head</td> <td>39.80</td> <td>Level</td> <td>4</td> <td></td> <td></td> </tr> <tr> <td>T heatsink</td> <td>51.68</td> <td>Low voltage</td> <td>27.90</td> <td></td> <td></td> </tr> <tr> <td>Pump pow.</td> <td>44.90</td> <td>5V supply</td> <td>5.00</td> <td></td> <td></td> </tr> <tr> <td>Pump rpm</td> <td>5460</td> <td>Fan voltage</td> <td>7.0</td> <td></td> <td></td> </tr> <tr> <td>Pumpe cur.</td> <td>1.68</td> <td>Cur. cons.</td> <td>2.84</td> <td></td> <td></td> </tr> </table>					T ext Pt	25.70	T int	-8			T ext analog	---.---	Mains U(%)	100.74			T ext serial	---.---	Mains frequ.	50			T cont. head	39.80	Level	4			T heatsink	51.68	Low voltage	27.90			Pump pow.	44.90	5V supply	5.00			Pump rpm	5460	Fan voltage	7.0			Pumpe cur.	1.68	Cur. cons.	2.84			<p>→ <b>Settings</b> → <b>Device status</b> → <b>Device data</b> → <b>Display</b></p> <ul style="list-style-type: none"> <li>– T ext shows various actual temperatures in °C from ext. Pt100 and the modules.</li> <li>– T cont. head and T heatsink are temperatures of electronics in the Master in °C.</li> <li>– Pump power in Watts, speed in rpm, current in ampere (A).</li> <li>– T<sub>int</sub> indicates the current internal bath temperature in °C.</li> <li>– Mains voltage in percentage (%) of nominal and frequency in hertz (Hz).</li> <li>– Level indicates the liquid level in the internal bath.</li> <li>– Voltage of power transformer, 5V supply and fan voltage in Volt.</li> <li>– Cur. cons.: Mains current consumption in Ampere.</li> </ul>	
T ext Pt	25.70	T int	-8																																																			
T ext analog	---.---	Mains U(%)	100.74																																																			
T ext serial	---.---	Mains frequ.	50																																																			
T cont. head	39.80	Level	4																																																			
T heatsink	51.68	Low voltage	27.90																																																			
Pump pow.	44.90	5V supply	5.00																																																			
Pump rpm	5460	Fan voltage	7.0																																																			
Pumpe cur.	1.68	Cur. cons.	2.84																																																			
Help	Menu	End	T <sub>set</sub>	T <sub>fix</sub>																																																		

## 9.1.5 Fault memory (Command)

For the analysis and localization of faults the Command version includes a fault memory in which up to 45 fault and alarm messages are saved.

Command				
No.	Source	Code	Type	Date Time
10	Safety	2	Alarm	-----
9	Safety	4	Warn.	28.08.03 15:32:02
8	Contro.	32	Error	17.07.03 10.:52:02
7	Contro.	3	Warn.	06.06.03 11:15:11
6	Contro.	9	Alarm	05.06.03 08:45:01
5	Contro.	3	Alarm	01.06.03 17:58:22
4	Contro.	4	Warn.	28.05.03 20:01:22
3	Contro.	5	Warn.	27.05.03 07:58:00
Low level				
Help	Menu	End	T <sub>set</sub>	T <sub>fix</sub>

– **Error store**

→ **Settings** → **Device status** → **Error store** → **Display**.

- The last message is at the top.
- Each message line can be marked with the cursor keys. The message appears in plain text in the footer.
- Under “Source”, the CAN node is displayed which signaled the fault.
- Code is the number, which in the Master is shown in the display until the cause has been rectified.
- Type: Alarm, Warning or Fault (Error).

## 9.2 Cleaning

### 9.2.1 Cleaning the surface of the device



Withdraw the equipment mains plug before cleaning!

Cleaning can be carried out with water to which a few drops of surfactant (washing-up liquid) have been added and using a damp cloth.



No water must enter the control section!



Carry out appropriate decontamination if hazardous material is spilt on or in the equipment.



The cleaning or decontamination method is determined by the user's specialist knowledge. In case of doubt, contact the manufacturer.

**9.2.2 Draining the water-cooled condenser**



**Important:** With the risk of frost (e.g. transport in winter), drain the condenser on water-cooled devices.

Remove the water hose on the water tap. Than open the solenoid valve for the water as described below. Blow compressed air in the water return hose Continue until all water has flowed out of the device.

Command		Start unfill condenser		
Pump Settings Graph Clock Programmer Interfaces Control Limits	Pump Level Ext.Pump Start unfill conden	- Open the device parameter menu via the soft key  <b>Menu</b> .	- Change from <b>Pump</b> → <b>Start unfill conden.</b> using  .	- Use  to open the solenoid valve for the water. The display changes automatically to the overview window.
Help   Menu   End   T <sub>set</sub> T <sub>fix</sub>		- To close the valve again selects this menu again. The item is called now <b>End unfill conden.</b>		

**9.3 Servicing, cleaning, repair and disposal information**



- Withdraw the mains plug before all service and repair work.
- Only specialists must carry out repairs in the control section!

**9.3.1 Servicing**

LAUDA Thermostats largely require no service. If the heat transfer liquid becomes contaminated, it should be replaced (⇒ 6.2).



- At the back of the Master head a main fuse switch  is located which interrupts the mains connection when an overload occurs. It is then in the "O" position and can be set in the "-" position again.
- If the fuse trips again, Service must locate the cause.
- Additionally, a safety fuse, which protects the low voltages, is situated on the mains board. If a fuse fails (→ mains lamp does not light) only replace with a fuse with the specified data (one x T (= slow-blow) 10 A, size 5 x 20 → the Fuse is located in the unit as shown below).

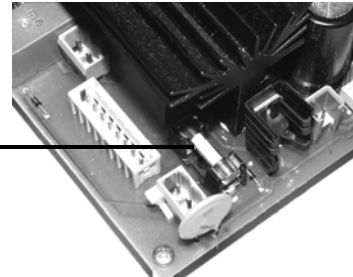
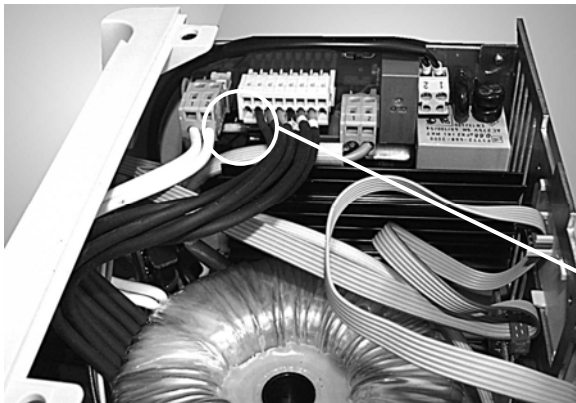

UL 533

### 9.3.2 Service intervals according to VDI 3033

System part	Frequency	Comment
	Each time of putting into operation and then	
<b>Complete device</b>		
External condition of the device	Monthly	
<b>Heat transfer liquid</b>		
Analysis of the heat transfer liquid	Half-yearly (and as required)	(⇒ 9.3.3)
<b>Heat transfer system</b>		
Sealing	Daily	External visual inspection
<b>External hoses</b>		
Material fatigue	Monthly	External visual inspection
<b>Cooling unit</b>		
Condenser cleaning	Monthly	(⇒ 9.3.4)
<b>Electronics</b>		
Over temperature protection	Quarterly	(⇒ 7.12.1)
Low level alarm/ warning	Quarterly	(⇒ 7.12.2)

### 9.3.3 Testing the heat transfer liquid

If required, the heat transfer liquid should be checked for fitness for use (e.g. when changing the method of operation), or at least half-yearly. Further use of the heat transfer liquid is only permissible if the inspection indicates this.

The test of the heat transfer liquid should take place according to DIN 51529; Testing of mineral oils and related products - Testing and evaluation of used heat transfer fluids.

Source: VDI 3033; DIN 51529.

### 9.3.4 Cleaning the condenser

#### 9.3.4.1 Air-cooled condenser

The SmartCool System refrigerating machine operates largely without servicing. So that the full cooling power is available, the heat exchanger (condenser) should be cleaned of dust at intervals of one month or longer depending on the operating period and dust level in the ambient air.



To do this, open the front grille, brush off the condenser and, where necessary, blow over with compressed air.

Extreme contamination is detected by the Proline SelfCheck Assistant, which then issues a warning.

#### 9.3.4.2 Water-cooled condenser

##### 9.3.4.2.1 Cleaning the dirt trap

At regular intervals of one month or longer, the dirt trap must be cleaned, depending on the degree of soiling.

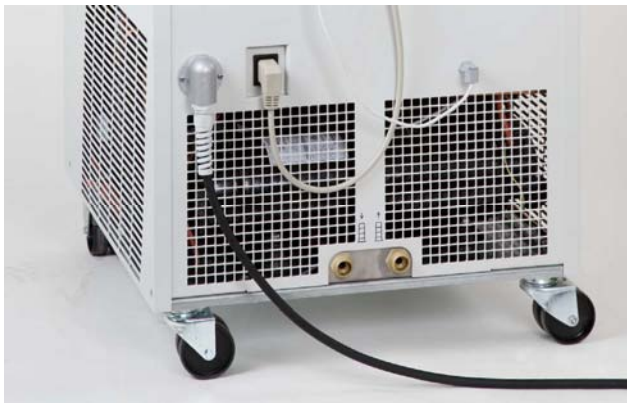

Take off the water feed hose on the device and remove the filter. Clean the filter and insert it again into the cooling water feed.

### 9.3.4.2.2 Decalcifying the water cooling circuit

At regular intervals of 3 months or longer, the water-cooled condenser must be decalcified or cleaned. This depends on the hardness of the cooling water and the degree of soiling. Drain according to (⇒ 9.2.2).

Required equipment:

- Two containers of approx. 10 to 20 liters volume.
- Use a suitable pump (drum pump) or a hose with funnel. Place the funnel as high as possible so that the device can fill quickly.
- Fit connecting hoses between container, pump, cooling water inlet and between cooling water outlet and back to container.

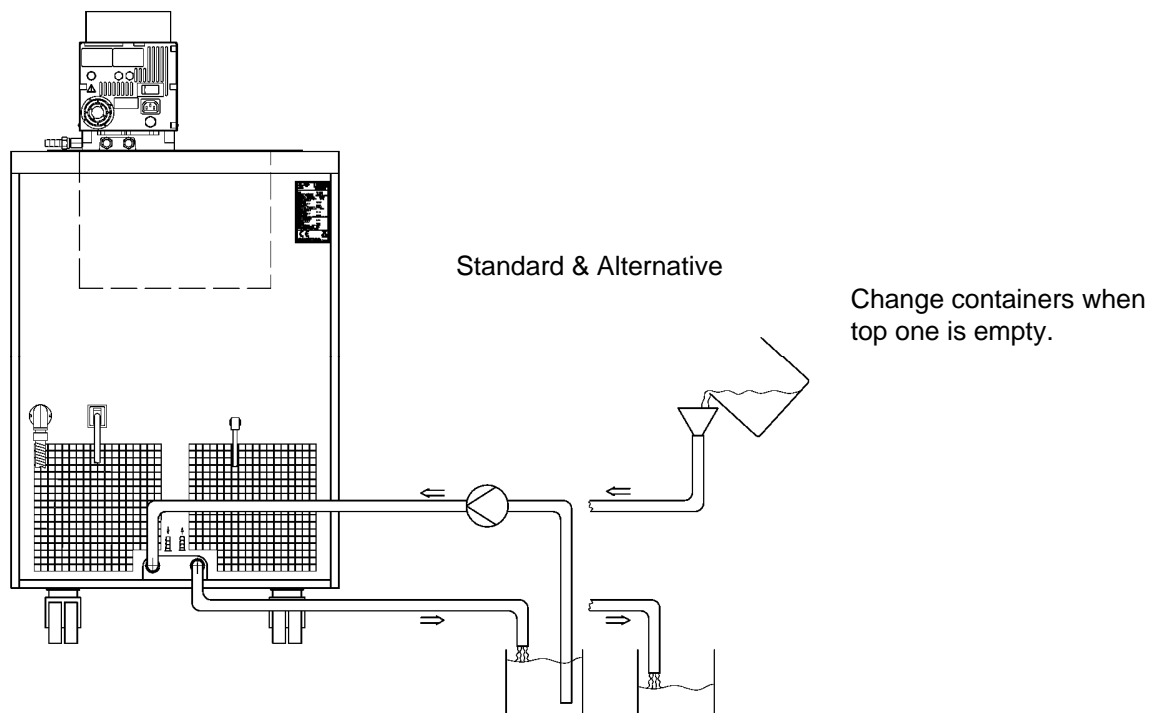

<b>Acting time:</b>	Continue the pump stage until most of the foamy reaction, usually at the start, has decayed. Generally, this is achieved after about 15 to 30 minutes.
<b>Decalcifier:</b>	Water with LAUDA Decalcifier LZB 126. It is essential to follow the safety instructions when handling the chemicals.
<b>Flushing:</b>	Allow at least 30 liters of water to flow through.

### 9.3.5 Repair information

If you need to send in a unit for repair, it is essential to first contact the LAUDA Service Constant Temperature Equipment ⇒ 9.3.7.



- When sending in the unit, ensure that it is carefully and properly packed. LAUDA cannot be held liable for any damage caused by improper packing.

### 9.3.6 Disposal information

#### 9.3.6.1 Disposal of the refrigerant

The refrigeration circuit is filled with CFC-free HFC refrigerant. The type and filling quantity can be read on the unit or on the rating plate. Repair and disposal only through a qualified refrigeration engineer!

Global Warming Potentials GWP [CO <sub>2</sub> = 1,0]			
Refrigerant	GWP <sub>(100a)</sub> *	Refrigerant	GWP <sub>(100a)</sub> *
R-23 / HFC-23	12 000	R-404A / HFC-404A	3784
R-134a / HFC-134a	1 300	R-508A / HFC-508A	11 939
* Time span 100 years – according to IPCC II (1996) → Basis for Kyoto Protocol			

#### 9.3.6.2 Disposal of the packaging

Packaging part	Material	Type of disposal
Pallet	– laminated wood – wood, for export (Douglas)	Reusable Pallet recycling
Inner and/ or outer packaging	Corrugated card board	Paper recycling
Foam inner packaging	Polyurethane foam (PUR) and bags polyethylene foil (PE)	Plastics recycling
Cushion-damper parts (Technoschaum)	Polyethylene (PE) Foam plastic slabs	Plastics recycling
Bubble wrap	Polyethylene foil (PE)	Plastics recycling
Airbags (Volume filler)	Air filled polyethylene bags (PE)	Plastics recycling
Molded parts	Polystyrene, foam (EPS, Styropor®)	Plastics recycling
User manual bags	Polypropylene foil (PP)	Plastics recycling
Fastening tape	Polyester tape, high strength	Plastics recycling

If recycling is not possible, the packaging parts can also be disposed of with the normal refuse.

### 9.3.7 Remedying faults

Before you contact the LAUDA Service Temperature Equipment (⇒ 9.4), check whether the problem can be remedied with the following instructions:

Fault	Possible remedy
Device does not cool or only very slowly.	<ol style="list-style-type: none"> <li>1. The module "Smart Cool" is set to "off" → Switch on "Smart Cool" module ⇒ 8.2.</li> <li>2. Dirty condenser → Clean condenser ⇒ 9.3.4.</li> <li>3. Temperature limit Til too high → Reduce temperature limit Til ⇒ 7.6.2.</li> </ol>
Device does not heat up or only very slowly.	Temperature limit Tih too low → Increase temperature limit Tih ⇒ 7.6.2..
The compressors are running although there is no necessity of cooling.	Regular device function (protectiv function).
Master: Alarm message <i>EEPP</i> Command: Overtemperature protection. ⇒ 7.12.1.	Wait until the outflow temperature has cooled below the overtemperature cut-off point or set the cut-off point higher than the outflow temperature.
Master: Warning message <i>LUArn 104</i> Command: Level very low (Imminent low level in the bath vessel). Master: Alarm message <i>LEUEL</i> Command: Low level. (Low level in the bath vessel) ⇒ 7.12.2.	<ol style="list-style-type: none"> <li>1. Check hoses, connections and load for whether a leaky location is present. → As applicable, rectify the leakage and top up the missing heat carrier liquid ⇒ 6.2 and 6.3.</li> <li>2. Check the Proline Kryomat for whether a leaky location is present. → If necessary, contact LAUDA Service Constant Temperature Equipment ⇒ 9.4.</li> <li>3. The liquid may drop due to cooling or degassing. → If necessary, top up the missing heat transfer liquid ⇒ 6.2 and 6.3.</li> </ol>
Master: Warning message <i>LUArn 103</i> Command: Level too high (Imminent excessive level in the bath vessel). Master: Alarm message <i>AL 6</i> Command: Level too high (Excessive level in the expansion vessel) ⇒ 7.12.4.	<ol style="list-style-type: none"> <li>1. Volume expansion of the heat transfer liquid during heating up.</li> <li>2. Moisture absorption in the heat transfer liquid.</li> </ol>

<p>Master: Alarm message <i>bLOC</i>                  Command: Pump blocked                  (Pump motor monitoring: Overload, blockage).                  ⇒ 7.12.5.</p>	<ol style="list-style-type: none"> <li>1. The viscosity of the heat transfer liquid is too high → change heat carrier liquid or raise the setpoint temperature.</li> <li>2. The pump is blocked. → Contact the LAUDA Service Constant Temperature Equipment ⇒ 9.4.</li> </ol>
<p>Master: Alarm message <i>PuLEU</i>                  Command: Low level (pump)                  (Pump motor monitoring: No load).                  ⇒ 7.12.6.</p>	<ol style="list-style-type: none"> <li>1. No liquid in the system. If this occurs, the level monitoring has failed. → Check whether the float in the expansion vessel is blocked by foreign bodies. Otherwise, contact LAUDA Service Constant Temperature Equipment ⇒ 9.4.</li> <li>2. With the option "open load" the device draws air out of the open load. → Move the return to the load.</li> </ol>
<p>Master: Alarm message <i>Error 11</i>                  Command: Overpressure                  (outflow pressure too high).</p>	<p>Pump level too high → Select a lower pump level                  ⇒ 7.5.3.</p>
<p>Compressor overtemperature</p>	<p>⇒ 7.12.7</p>
<p>Three-phase current</p>	<p>⇒ 7.12.8</p>

## 9.4 Help desk and ordering replacement parts

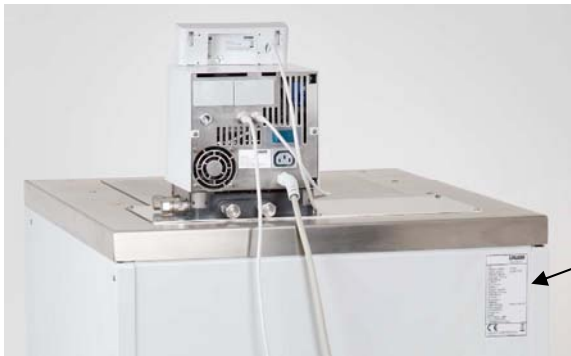

When ordering spares please quote instrument type and serial number from the name-plate. This avoids queries and supply of incorrect items.

Name-plate

The serial number is combined like following, for example **LUK248-09-0001**

LUK 248	=	catalogue number,
09	=	manufacturing year 2009,
0001	=	continuous numbering.



Your contact for service and support:

**Service Constant Temperature Equipment**  
**Telephone: 0049 9343/ 503-236 (English and German)**  
**Fax: 0049 9343/ 503-283**  
**E-mail [service@lauda.de](mailto:service@lauda.de)**

We are available any time for your queries, suggestions and criticism.

**LAUDA DR. R. WOBSE GMBH & CO. KG**  
**P.O. Box 1251**  
**97912 Lauda-Koenigshofen**  
**Germany**

Telephone: 0049 9343/ 503-0  
Fax: 0049 9343/ 503-222  
E-mail [info@lauda.de](mailto:info@lauda.de)  
Internet <http://www.lauda.de>

## 10 Accessories

Description	Application	LAUDA Catalogue number:
LAUDA Wintherm Plus PC Program	Control of the thermostat, online display of all values as a graph with free choice of time frame. Incl. RS 232 cable (2m)	LDSM2002
RS232/ 485 Interface modules	Digital Communication, operation of the LAUDA PC software Wintherm Plus ⇒ 8.3	LRZ 913
RS 232 Cable (2m)	Thermostat-PC Sub-D (9 pin. 9 pin)	EKS 037
RS 232 Cable (5m)	Thermostat-PC Sub-D (9 pin. 9 pin)	EKS 057
Analogue module	Current and voltage interface ⇒ 8.4	LRZ 912
Relays module with 3 input and 3 output channels	Import and export of thermostat signals ⇒ 8.5.1	LRZ 915
Relays module with 1 input and 1 output channel	NAMUR NE28 functionality ⇒ 8.5.2	LRZ 914
T-piece adapter cable for the LAUDA internal bus (LiBus) ①.	For the connection of further LiBus components (with heating thermostats two LiBus ① connections are not occupied and one with cooling thermostats)	EKS 073
Extension for LiBus ① 5m	For LiBus ① components, but especially for remote operation with the command console.	EKS 068
Extension for LiBus ① 25m		EKS 069
Automatic refill device with LiBus ① control.	Evaporating heat transfer liquid is automatically topped up.	LCZ 9661
Shut-off unit with LiBus ① control.	Prevents the return of cooling liquid into the bath from external containers located above the bath.	LCZ 9673
Level controller without reverse-flow protection, mechanical function.	Keeps the liquid level in an open external bath at a constant level.	LCZ 0660

Raising platforms, application frames etc.

We will inform you about other accessories on request ⇒ 9.3.7. Also, refer to our special and accessory brochures.

① LiBus = LAUDA internal BUS (based on CAN).

### 11 Technical data and diagrams

The figures have been determined according to DIN 12876.

				RP 3050 C	RP 3050 CW	RP 4050 C	RP 4050 CW		
Operating temp.- ACC range		°C	-50...200						
Ambient temp. range		°C	5...40						
Relative humidity			maximum relative humidity 80 % for temperatures up to 31 °C, decreasing linearly to 50 % relative humidity at 40 °C						
Temperature range for storage		°C	-20...44 at water-cooled devices the condenser must be completely empty (⇒ 9.2.2)						
Setting resolution		°C	0.1 / 0.01 (Master); 0.01 (Command)						
Display resolution		°C	Master: 0.01 Command: 0,1 / 0,01 / 0,001						
Display accuracy			±0.2 °C can be calibrated additively (→ Section 1.2 last Point)						
Temperature stability		±K	0.05						
Safety equipment		Class	III, FL suitable for flammable and non-flammable liquids						
Maximum cooling water consumption: temperature 15 °C, pressure 3 bar ④		[L/h]	X		700	X		700	
Water-cooling connections (DIN EN 10226-1)			X		G 3/4"	X		G 3/4"	
Heater power 400 V; 50 Hz		kW	maximum 3.5						
Cooling power at 20°C t <sub>amb</sub> @ bath temp. (Pump Level 6)	with heat transfer oil	200 °C	kW	Data coming soon	Data coming soon	5.00	7.00		
	with ethanol	20 °C	kW			5.00	6.00		
		0 °C	kW			3.0	3.5		
		-20 °C	kW			1.6	1.8		
		-30 °C	kW			1.0	1.1		
		-40 °C	kW			0.5	0.6		
		-50 °C	kW			0.25	0.25		
		-60 °C	kW	X		X		X	
		-70 °C	kW	X		X		X	
		-80 °C	kW	X		X		X	
	-90 °C	kW	X		X		X		
Pump type			Pressure pump, 4 power levels (level 5 to 8)						
Discharge pressure max.		bar	0.5 at pump power level 8						
Flow rate max. (pressure)		L/min	19 at pump power level 8						
Hose connections			Thread M16x1; olives 13 mm external diameter						
Bath volume from...to		L	23...31			32...44			
Bath opening B x L		mm	350 x 200			350 x 350			
Bath depth / usable depth		mm	250						
Height to top of bath		mm	905						
Overall dims. B x L		mm	600 x 700						

		<b>RP 3050 C</b>	<b>RP 3050 CW</b>	<b>RP 4050 C</b>	<b>RP 4050 CW</b>
Overall dim. H	mm	1160			
Weight	kg	155			
Power consumption 400 V; 50 Hz	kW	maximum 5.0			
Ingress protection rating → IP Code accord. to IEC 60529		IP 2 1			
Protection class		Protection class 1 according to DIN EN 61140 VDE 0140-1			
EC Directives		The units are conformable to directives of the European Parliament and of the council: 2004/108/EC electromagnetic compatibility and 2006/95/EC electrical equipment designed for use within certain voltage limits. The units carry the CE mark.			
Class to EMC-standard DIN EN 61326-1 VDE 0843- 20-1:2006-10 notice only valid for EU- countries) for Canada and the USA		Class B (⇒ 1.1)  Class A (⇒ 1.1)			

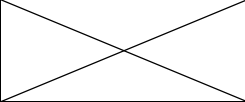
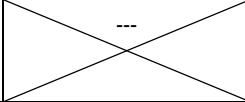
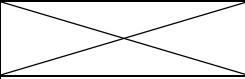
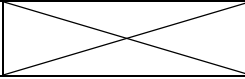
			RP 3090 C	RP 3090 CW	RP 4090 C	RP 4090 CW	
Operating temp.- ACC range	°C	-90...200					
Ambient temp. range	°C	5...40					
Relative humidity		maximum relative humidity 80 % for temperatures up to 31 °C, decreasing linearly to 50 % relative humidity at 40 °C					
Temperature range for storage	°C	-20...44 at water-cooled devices the condenser must be completely empty (⇒ 9.2.2)					
Setting resolution	°C	0.1 / 0.01 (Master); 0.01 (Command)					
Display resolution	°C	Master: 0.01 Command: 0,1 / 0,01 / 0,001					
Display accuracy		±0.2 °C can be calibrated additively (→ Section 1.2 last Point)					
Temperature stability	±K	0.05					
Safety equipment	Class	III, FL suitable for flammable and non-flammable liquids					
Maximum cooling water consumption: temperature 15 °C, pressure 3 bar ④	[L/h]		700		800		
Water-cooling connections (DIN EN 10226-1)			G ¾"		G ¾"		
Heater power 400 V; 50 Hz	kW	maximum 3.5					
Cooling power at 20°C t <sub>amb</sub> @ bath temp. (Pump Level 6)	with heat transfer oil	200 °C	kW	3.0	4.0	3.00	4.00
	with ethanol	20 °C	kW	3.0	4.0	3.00	4.00
		0 °C	kW	2.9	3.7	2.90	3.70
		-20 °C	kW	2.5	3.1	2.5	3.1
		-30 °C	kW	2.3	2.7	2.3	2.7
		-40 °C	kW	2.0	2.3	2.0	2.3
		-50 °C	kW	1.6	1.8	1.6	1.8
		-60 °C	kW	1.3	1.4	1.3	1.4
		-70 °C	kW	0.8	0.9	0.8	0.9
		-80 °C	kW	0.5	0.5	0.5	0.5
-90 °C	kW	0.15	0.15	0.15	0.15		
Pump type		Pressure pump, 4 power levels (level 5 to 8)					
Discharge pressure max.	bar	0.5 at pump power level 8					
Flow rate max. (pressure)	L/min	19 at pump power level 8					
Hose connections		Thread M16x1; olives 13 mm external diameter					
Bath volume from...to	L	23...31			32...44		
Bath opening B x L	mm	350 x 200			350 x 350		
Bath depth / usable depth	mm	250					
Height to top of bath	mm	905					
Overall dims. B x L	mm	600 x 700					
Overall dim. H	mm	1160					

		RP 3090 C	RP 3090 CW	RP 4090 C	RP 4090 CW
Weight	kg	155			
Power consumption 400 V; 50 Hz	kW	maximum 5.0			
Ingress protection rating → IP Code accord. to IEC 60529		IP 2 1			
Protection class		Protection class 1 according to DIN EN 61140 VDE 0140-1			
EC Directives		The units are conformable to directives of the European Parliament and of the council: 2004/108/EC electromagnetic compatibility and 2006/95/EC electrical equipment designed for use within certain voltage limits. The units carry the CE mark.			
Class to EMC-standard DIN EN 61326-1 VDE 0843- 20-1:2006-10 (notice only valid for EU- countries) for Canada and the USA		Class B (⇒ 1.1)  Class A (⇒ 1.1)			

**Catalogue numbers and mains connection data**

**Proline Kryomats air-cooled**

Catalogue number	RP 3050 C	RP 4050 C	RP 3090 C	RP 4090 C
Mains connection data				
400 V +8/-10 %; 3/N/PE~50 Hz	LUK 239	LUK 241	LUK 245	LUK 247

**Proline Kryomats water-cooled**

Catalogue number	RP 3050 CW	RP 4050 CW	RP 3090 CW	RP 4090 CW
Mains connection data				
400 V +8/-10 %; 3/N/PE~50 Hz	LUK 240	LUK 242	LUK 246	LUK 248

Technical modifications reserved.

## Cooling curves

### Cooling curves 1-stage

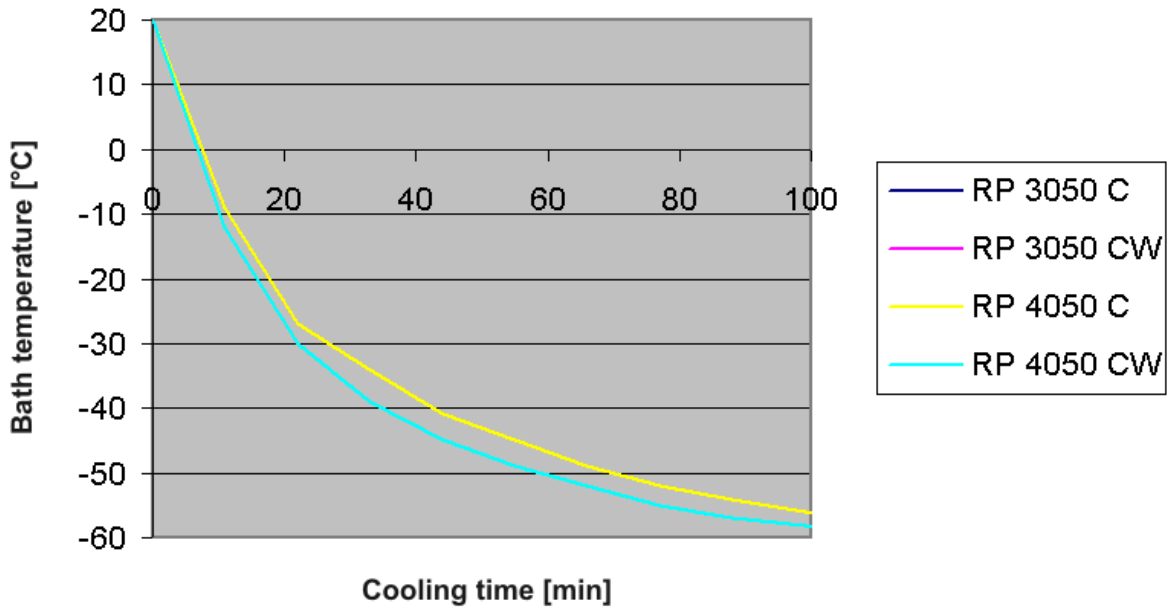

### Cooling curves cascades

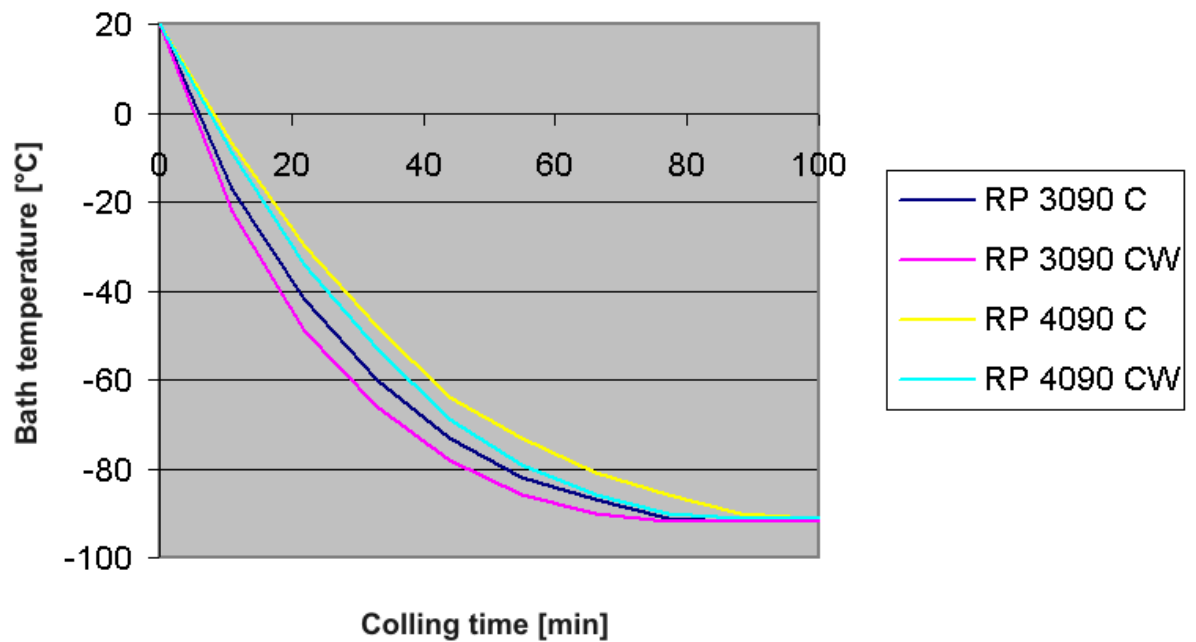

Cooling curves; Bath closed; Heat transfer liquid: Ethanol; Time in minutes; Temperature in °C.

Influence of ambient temperature at air-cooled Kryomats

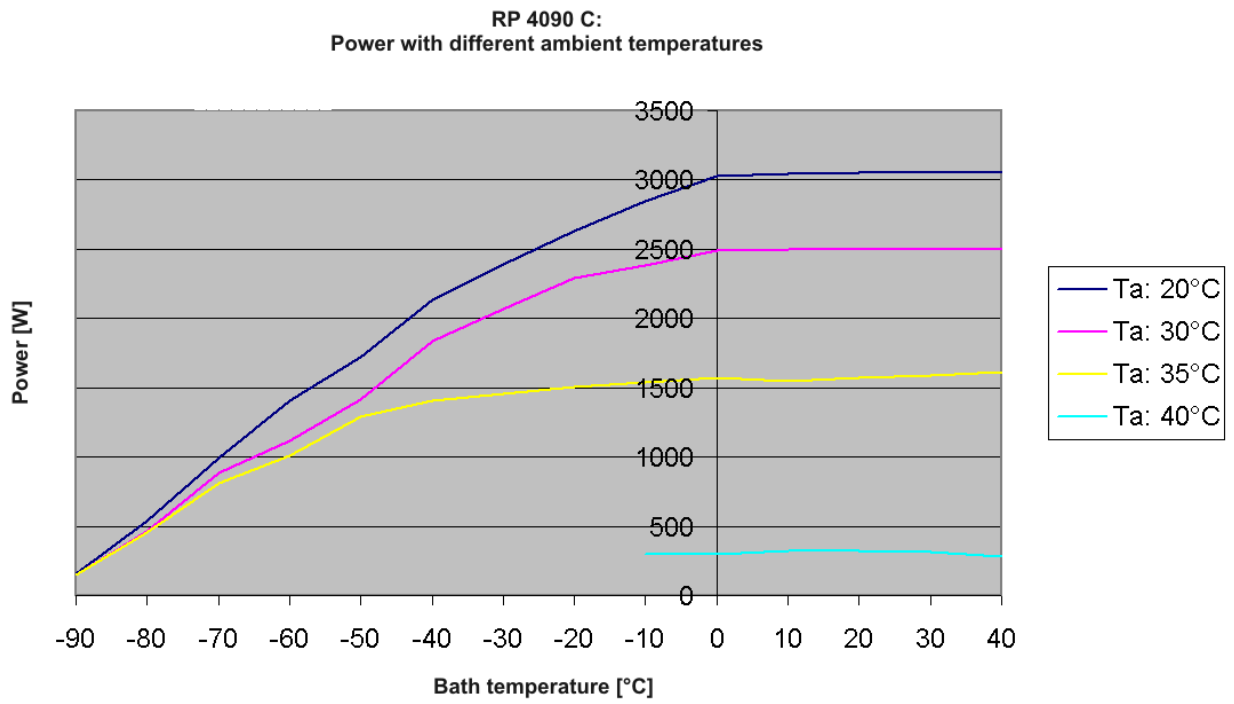



**P**

Pause program ..... 63  
 Power level, pump ..... 18  
 Profibus Modules ..... 20  
 Program sequence ..... 68  
 Programmer ..... 60, 62  
 P<sub>U</sub> pump power levels ..... 44  
 Pump ..... 17  
     Connector ..... 17  
     Low level ..... 80  
     Program setting ..... 67  
     Unused connectors ..... 30  
**Pump Level** ..... 45  
 Pump-motor supervision  
     Dry running ..... 79  
     Overload ..... 79

**R**

Ramp ..... 60  
 Ramp function ..... 70  
 Rating label ..... 104  
 Refrigerant ..... 101  
 Refrigerating machine ..... 20  
 Refrigerating unit ..... 20  
**Remedying faults** ..... 102  
 Repair information ..... 100  
 RS 232/ RS 485 Interface ..... 84  
 RS232 / 485 Interface module ..... 19

**S**

S<sub>AFE</sub> keyboard locking ..... 39  
 Safety functions ..... 75  
 Safety information ..... 7  
 Safety notes ..... 3  
 Safety system ..... 18  
 Screen displays ..... 35

**Screen** Graph recorder ..... 58  
 Sealing caps ..... 26  
 Segment ..... 60  
 Segment "Start" ..... 61  
 Segment time ..... 66  
 Select program ..... 62  
 SelfCheck Assistant ..... 18, 75  
 Self-test ..... 32  
 Serial interfaces RS232/ 485 ..... 92  
 Serial number ..... 104  
 Serial numbers ..... 95  
 Service contact ..... 104  
 Service intervals ..... 98  
 Servicing ..... 97  
**Set date** ..... 49  
 S<sub>EE</sub> setpoint setting ..... 41  
**Set time** ..... 49  
 Setpoint offset ..... 53  
 Setting of numerical values ..... 34  
 Setting pump power ..... 44  
 Signs in this manual ..... 6  
 SmartCool technology ..... 20  
 Socket 10S ..... 43  
 Soft keys ..... 35  
 Software version ..... 95  
**Sounds** ..... 55  
 Spare parts ..... 104  
 Standard window ..... 36  
 Standby ..... 33  
 Standby activation ..... 35  
 Starting up ..... 31  
**Status** ..... 62, 63  
 Super window ..... 37  
 Switching off ..... 33

**T**

T end °C ..... 65  
 Technical data ..... 106

**TEMP** Overtemperature alarm ..... 76  
 Temperature ..... 50  
     display resolution ..... 50  
     External probe ..... 43  
     Gradient ..... 43  
     Limits ..... 52  
     Setpoint setting ..... 41  
**Temperature Limits** ..... 52  
 T<sub>ext</sub> external temperature ..... 44  
**T<sub>fix</sub>** Default setpoint temp. .... 42  
 Time ..... 66  
**Timer** ..... 71  
 Timer function ..... 71  
 Tolerance (Program) ..... 66  
 Tolerance range ..... 61  
**T<sub>set</sub>** Setpoint temperature setting ..... 42  
 Tv manual/auto ..... 74  
 Type designation ..... 17  
 Type of start mode ..... 51

**U**

Unlocking ..... 39

**V**

VarioFlex pump ..... 17  
 Version of the software ..... 95

**W**

Warnings ..... 75  
**Weekplan** ..... 71  
 Works settings ..... 54  
**WARN** Warning ..... 78  
**WARN 103** High-level warning ..... 78



**An / To / A:**

LAUDA Dr. R. Wobser • LAUDA Service Center • Fax: +49 (0) 9343 - 503-222

**Von / From / De :**

Firma / Company / Entreprise: \_\_\_\_\_

Straße / Street / Rue: \_\_\_\_\_

Ort / City / Ville: \_\_\_\_\_

Tel.: \_\_\_\_\_

Fax: \_\_\_\_\_

Betreiber / Responsible person / Personne responsable: \_\_\_\_\_

Hiermit bestätigen wir, daß nachfolgend aufgeführtes LAUDA-Gerät (Daten vom Typenschild):

We herewith confirm that the following LAUDA-equipment (see label):

Par la présente nous confirmons que l'appareil LAUDA (voir plaque signalétique):

Typ / Type / Type :	Serien-Nr. / Serial no. / No. de série:

mit folgendem Medium betrieben wurde

was used with the below mentioned media

a été utilisé avec le liquide suivant

---



---



---



---

**Darüber hinaus bestätigen wir, daß das oben aufgeführte Gerät sorgfältig gereinigt wurde, die Anschlüsse verschlossen sind, und sich weder giftige, aggressive, radioaktive noch andere gefährliche Medien in dem Gerät befinden.**

**Additionally we confirm that the above mentioned equipment has been cleaned, that all connectors are closed and that there are no poisonous, aggressive, radioactive or other dangerous media inside the equipment.**

**D'autre part, nous confirmons que l'appareil mentionné ci-dessus a été nettoyé correctement, que les tubulures sont fermées et qu'il n'y a aucun produit toxique, agressif, radioactif ou autre produit nocif ou dangereux dans la cuve.**

Stempel Seal / Cachet.	Datum Date / Date	Betreiber Responsible person / Personne responsable

Formblatt / Form / Formulaire:

Unbedenk.doc

Erstellt / published / établi:

LSC

Änd.-Stand / config-level / Version:

0.1

Datum / date:

30.10.1998

**LAUDA DR. R. WOBSE** GmbH & Co. KG

Pfarrstraße 41/43

D - 97922 Lauda-Königshofen

Internet: <http://www.lauda.de>

Tel: +49 (0)9343 / 503-0

Fax: +49 (0)9343 / 503-222

E-mail: [info@lauda.de](mailto:info@lauda.de)